

Alternate Operation Relay 61F-AN/-APN2

CSM_61F-AN_-APN2_DS_E_4_3

Increases Motor Life and Enables Operating Only One Pump When Cleaning Tanks or as an Emergency Measure for Pump Failures.

- Electronic Relay with the same operation as the G4Q Latching Relay. Compared with the G4Q, the 61F-AN/-APN2 has a shorter power supply application time and no restrictions on mounting direction.
- Compact Models (61F-AN) and Compact Plug-in Models (61F-APN2) available.

Note: A changeover switch must be included in the sequence to enable operating only one pump.

 Refer to *Safety Precautions for Floatless Level Controllers*.

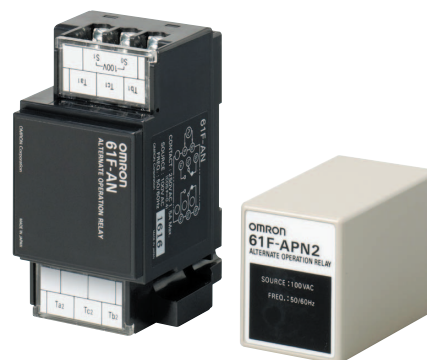

Ordering Information

Type	Model
Alternate Operation Relay	61F-AN
	61F-APN2

Note: When ordering, specify the desired operating voltage at the end of the model number.

Example: 61F-AN [220VAC]

_____ Desired supply voltage

Specifications

Ratings

Supply voltage	100, 110, 200, 220 VAC; 50/60 Hz
Operating voltage range	85% to 110% of rated voltage
Power consumption	3 VA
Accessories	Hold-down clip PFC-N8 *

* Hold-down clip PFC-N8 is attached only 61F-APN2.

Contact Ratings (with G2RK Keep Relay)

Item	Resistive load ($\cos\phi = 1$)	Inductive load ($\cos\phi = 0.4, L/R = 7 \text{ ms}$)
Max. load	3 A at 250 VAC	1.5 A at 250 VAC
Carry contact	3 A	
Max. operating current	3 A	
Max. switching capacity	750 VA	375 VA

Characteristics

Response time	Operate: 25 ms max. Release: 30 ms max.
Minimum pulse width	Min. ON time: 40 ms min. Min. OFF time: 200 ms min.
Insulation resistance	100 M Ω min. at 500 VDC (between each terminal and power supply)
Dielectric strength	2,000 VAC, 50/60 Hz for 1 min (between each terminal and power supply)
Vibration resistance	10 to 55 Hz, 1-mm double amplitude
Shock resistance	10 G (approx. 98 m/s ²)
Life expectancy	Mechanical: 1,000,000 operations (at operating frequency of 1,800 operations/hour) Electrical: 100,000 operations min. (rated load)
Ambient temperature	Operating: -10 to 55°C
Ambient humidity	Operating: 45% to 85% RH
Weight	61F-AN: Approx. 215 g 61F-APN2: Approx. 190 g

Time Chart for Alternate Operation of Water Supply

When the 61F-A□ Alternate Operation Relay is combined with a Floatless Level Switch, the Relay output contacts switch (break) while the contactor is engaged. The Relay output contacts will not switch simultaneously with engaging the contactor. In other words, the contactor or other load is switched with the output contacts from the Floatless Level Switch, not directly with the output contacts from the 61F-A□ Alternate Operation Relay. Using water supply as an

example, after the control level is reached and the 61F Controllers' NC contacts turn OFF (break), the Relay's output contacts switch. The next time the 61F Controller's NC contacts turn ON, the output contacts have already switched. Thus, only the continuous carry current needs to be considered for the load capacity of the 61F-APN2, enabling application to the rated carry current of 3 A.

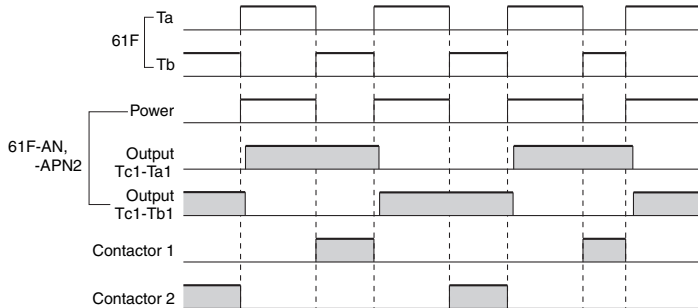

61F-AN (Compact Model)

Used in combination with a 61F-G□N Floatless Level Switch.

Operation

- The 61F-AN is used in combination with a Floatless Level Switch for alternate operation when using two pumps for level control in one location.
- When power is applied to the input terminals S₀ and S₂, NO contacts Tc₁ and Ta₁, and NO contacts Ta₂ and Tc₂ are turned ON via the alternate operation control circuit and the output circuit. This state is held with a magnetic lock even if the power supply is turned OFF.
- When power is applied to the input terminals again, the NO contacts are turned OFF and the NC contacts Tc₁ and Tb₁ and NC contacts Ta₂ and Tc₂ are turned ON. This state is held with a magnetic lock even if the power supply is turned OFF.
- The above operation is repeated each time the power supply is turned ON.
(Power Supply Pulse Response Method)

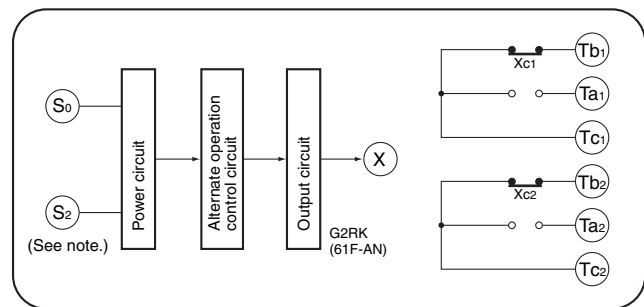

(Note: The above diagram is for a rated voltage of 200 or 220 VAC. Power is supplied to S₀ and S₁ for 100 or 110 VAC.)
Connections (Refer to connection diagram.)

61F-APN2 (Compact Plug-in Model)

Used in combination with a Floatless Level Switch.

Operation

- The 61F-APN2 is used in combination with a Floatless Level Switch for alternate operation when using two pumps for level control in one location.
- When power is applied to the input terminals 2 and 7, NO contacts 1 and 3, and NO contacts 6 and 8 are turned ON via the alternate operation control circuit and the output circuit. This state is held with a magnetic lock even if the power supply is turned OFF.
- When power is applied to the input terminals again, the NO contacts are turned OFF and the NC contacts 1 and 4 and NC contacts 5 and 8 are turned ON. This state is held with a magnetic lock even if the power supply is turned OFF.
- The above operation is repeated each time the power supply is turned ON.
(Power Supply Pulse Response Method)

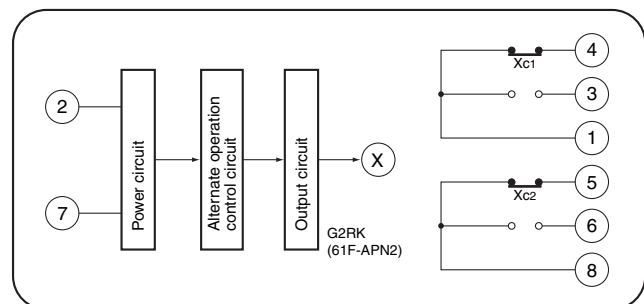

Note: Refer to *Connecting Sockets, Mounting Brackets, DIN Rails* for the applicable Sockets.

Connections (Refer to connection diagram.)

- Connect output terminal Ta in the 61F-G example (page 5) to input terminal 2 on the 61F-APN2.
- Connect coil terminal A on each of the two contactors to the switching contact terminals 3 and 4 on the 61F-APN2.
- Use the switching contact terminals 5 and 6 on the 61F-APN2 to control the operation of the two pumps.
- The power supply of the 61F-APN2 is 100, 110, 200, or 220 VAC. Be sure to use the correct power supply.

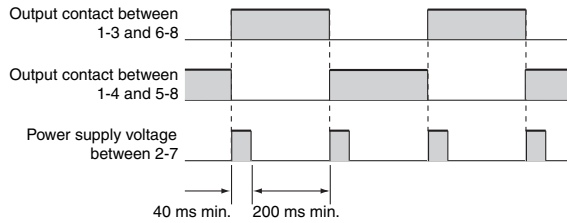

■ Connections

Combining with the 61F-GN

61F-AN

Dimensions:
page 17



Combining with the 61F-GN

Water Supply

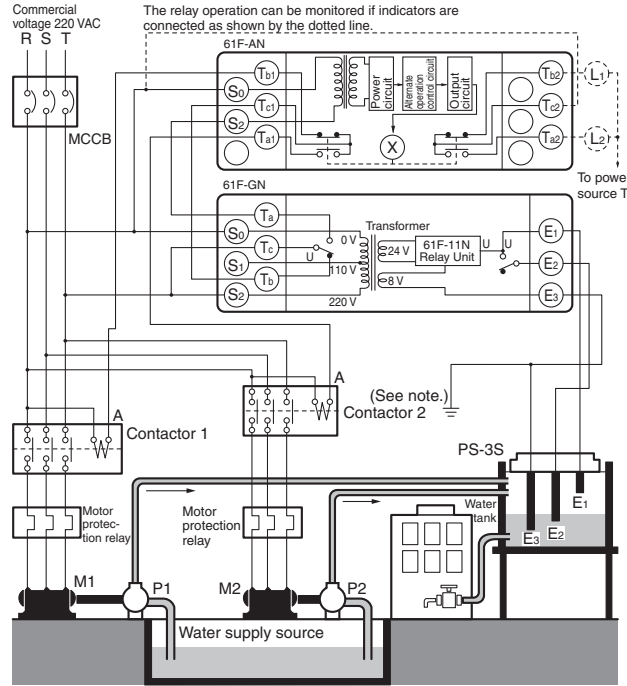

Note: Be sure to ground the common Electrode E₃ (the longest Electrode).

Drainage

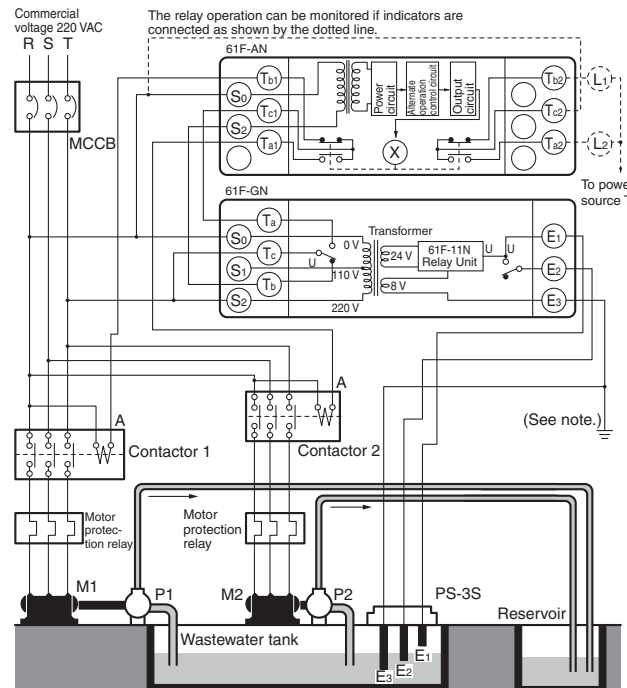

Note: Be sure to ground the common Electrode E₃ (the longest Electrode).

Combining with the 61F-G1N

61F-AN

Dimensions:
page 17

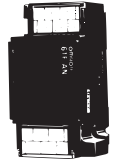

Combining with the 61F-G1N

Water Supply

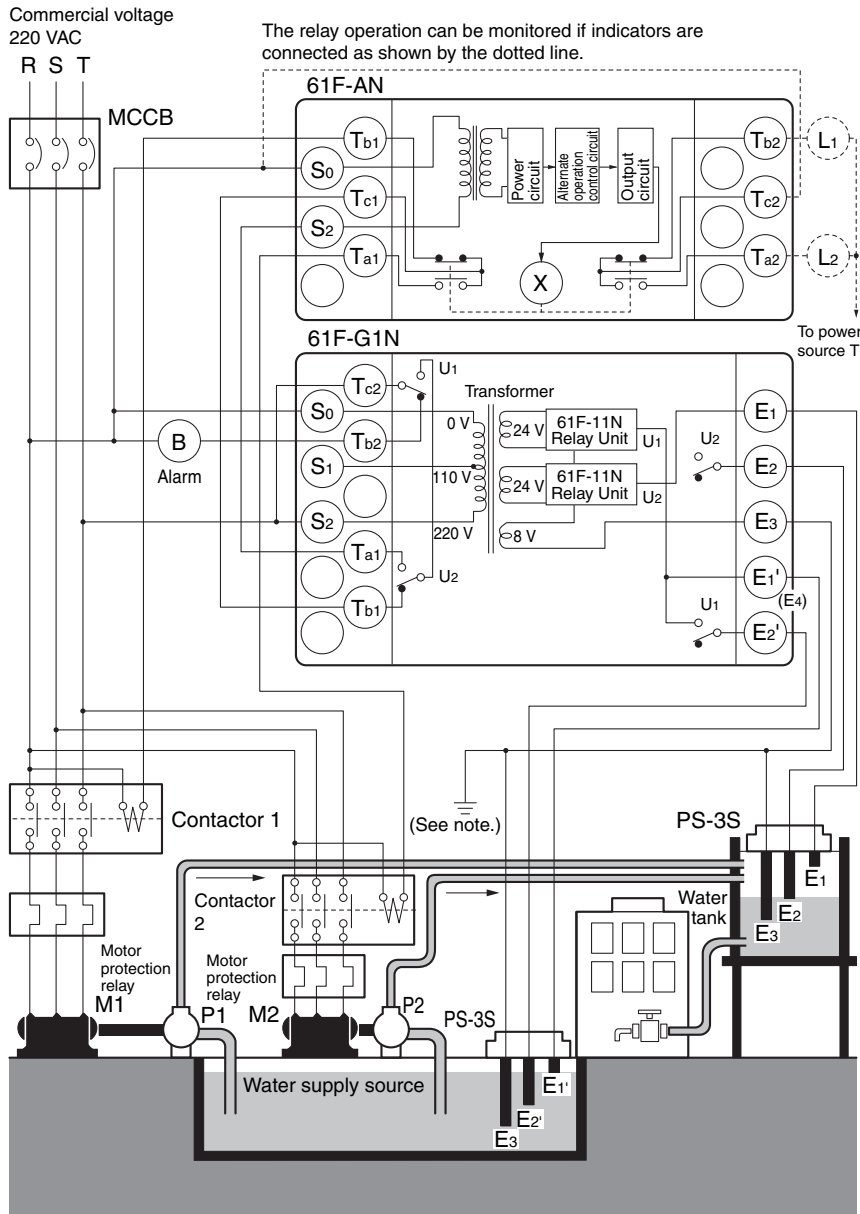

Drainage

The 61F-G1N is to be used only for supplying water and cannot be used for alternate operation for controlling drainage.

Combining with the 61F-G1

61F-APN2

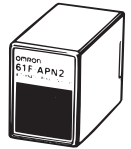

Dimensions:
page 17

Combining with the 61F-G1

Water Supply

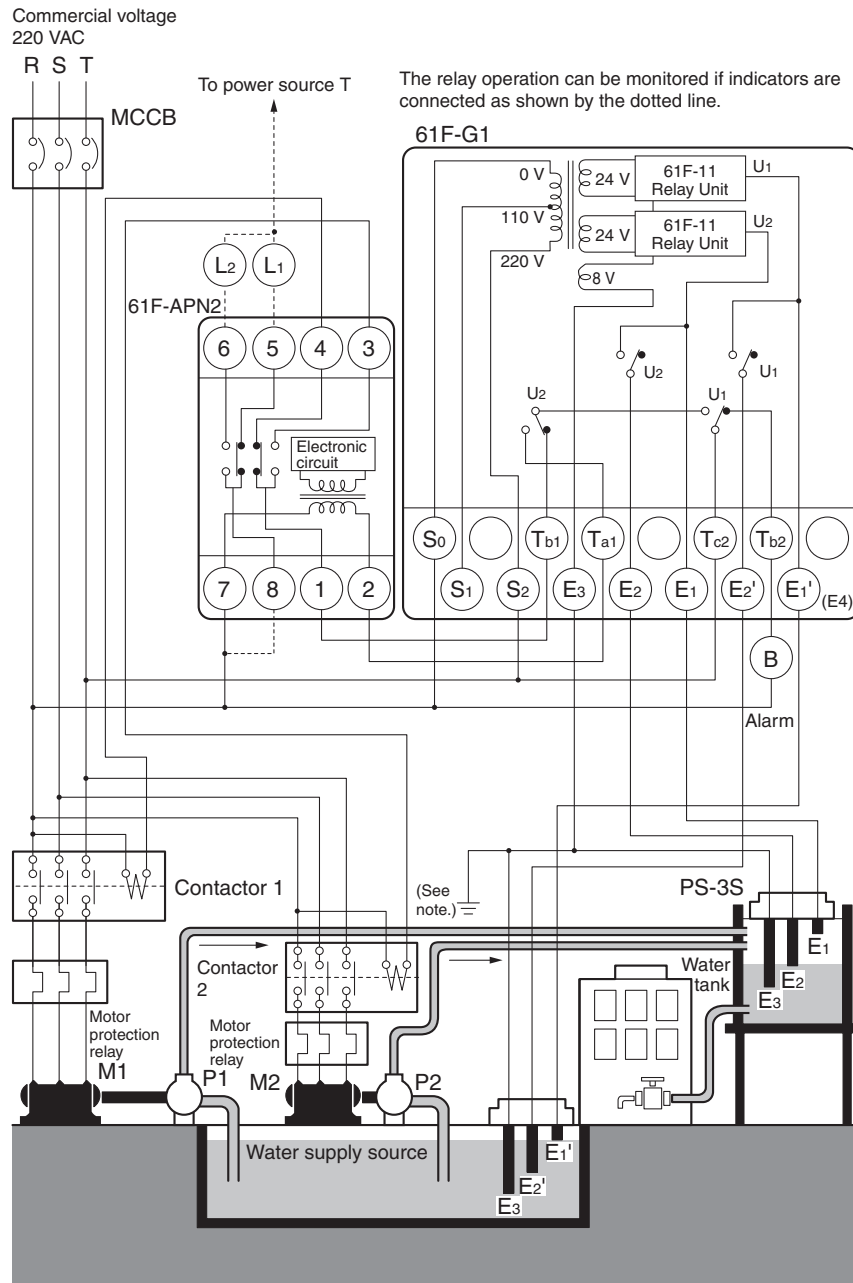

Note: Be sure to ground the common Electrode E₃ (the longest Electrode).

Water Drainage

The 61F-G1N is to be used only for supplying water and cannot be used for alternate operation for controlling drainage.

Combining with the 61F-G2N

61F-AN

Dimensions:
page 17

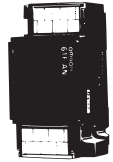

Combining with the 61F-G2N

Water Supply

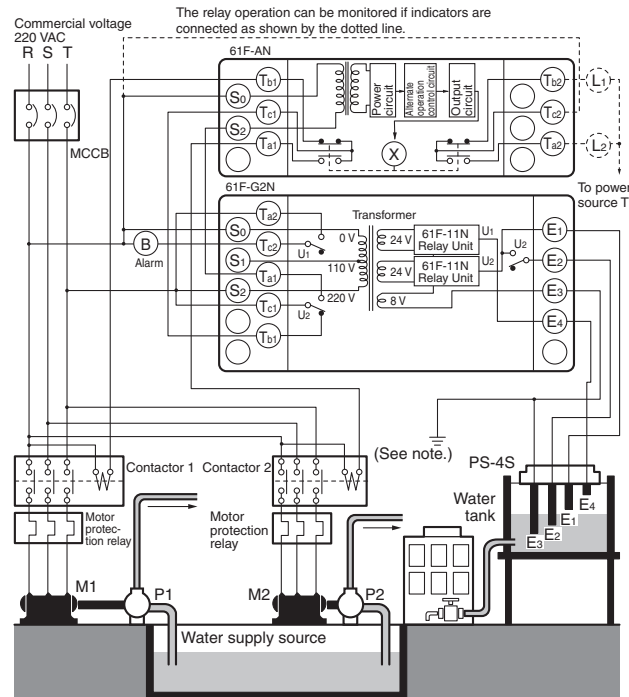

Note: Be sure to ground the common Electrode E₃ (the longest Electrode).

Drainage

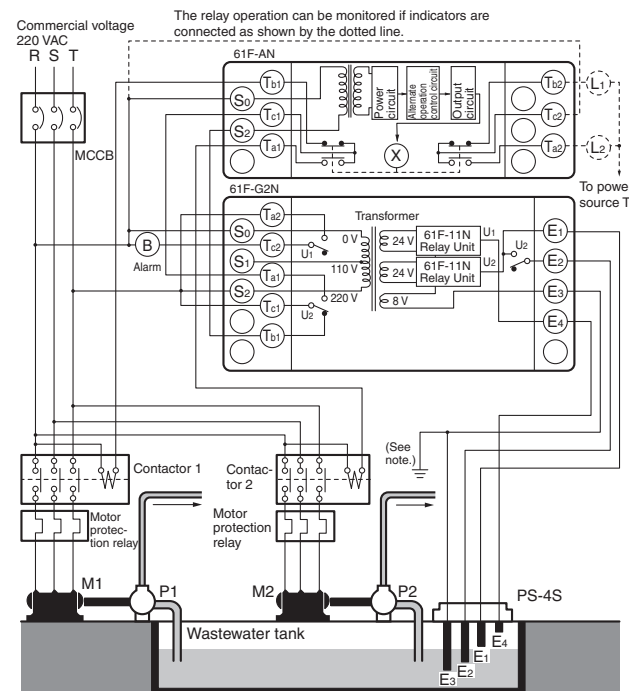

Note: Be sure to ground the common Electrode E₃ (the longest Electrode).

Combining with the 61F-G2

61F-APN2

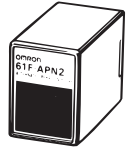

Dimensions:
page 17

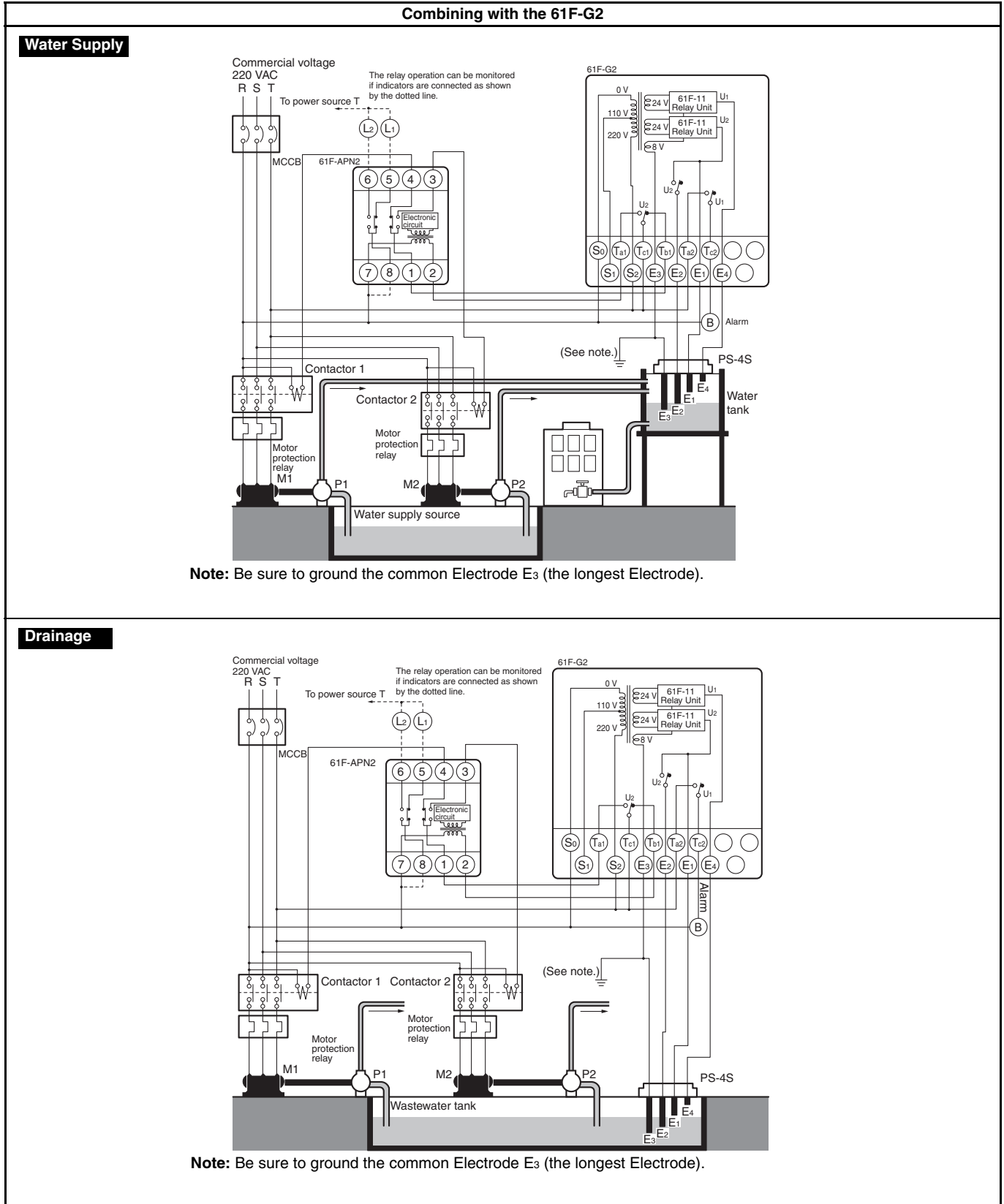

Combining with the 61F-G3N

61F-AN

Dimensions:
page 17

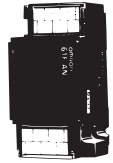

Combining with the 61F-G3N

Water Supply

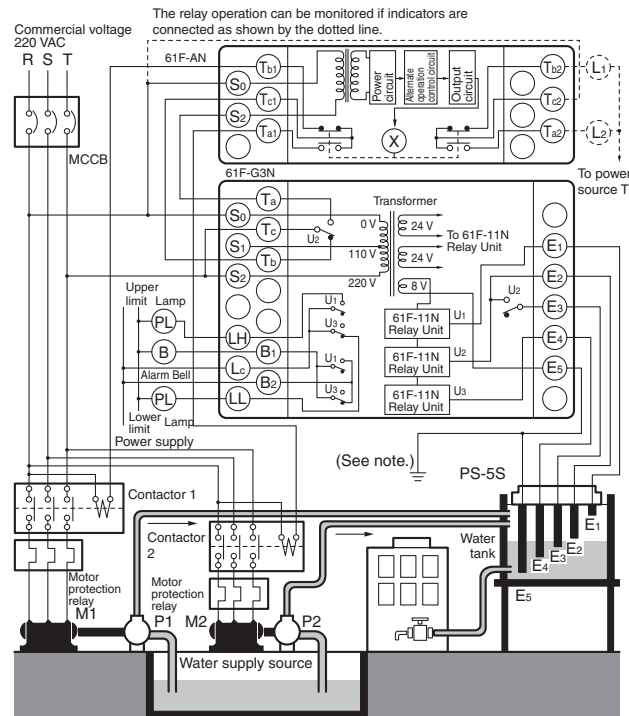

Note: Be sure to ground the common Electrode E₃ (the longest Electrode).

Drainage

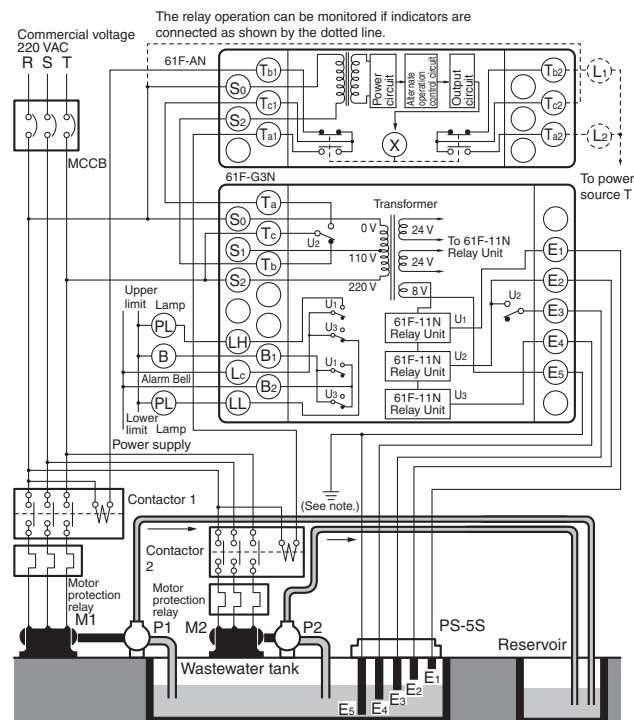

Note: Be sure to ground the common Electrode E₃ (the longest Electrode).

Combining with the 61F-G3

61F-APN2

Dimensions:
page 17

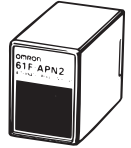

Combining with the 61F-G3

Water Supply

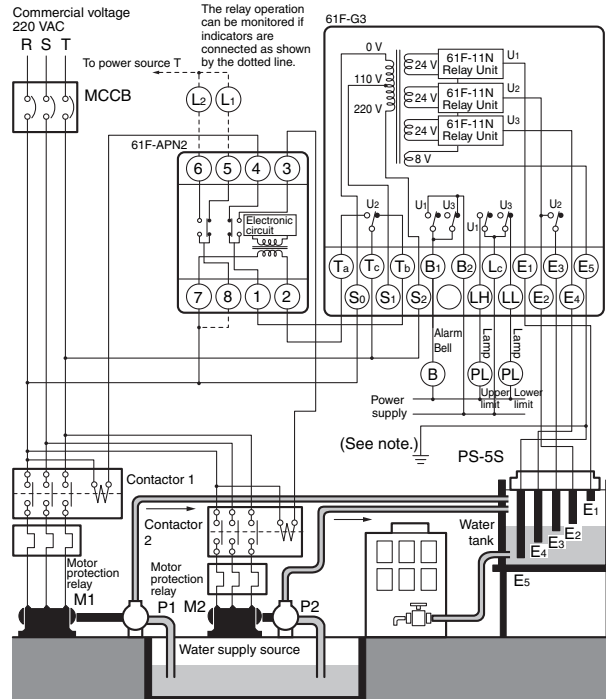

Note: Be sure to ground the common Electrode E3 (the longest Electrode).

Drainage

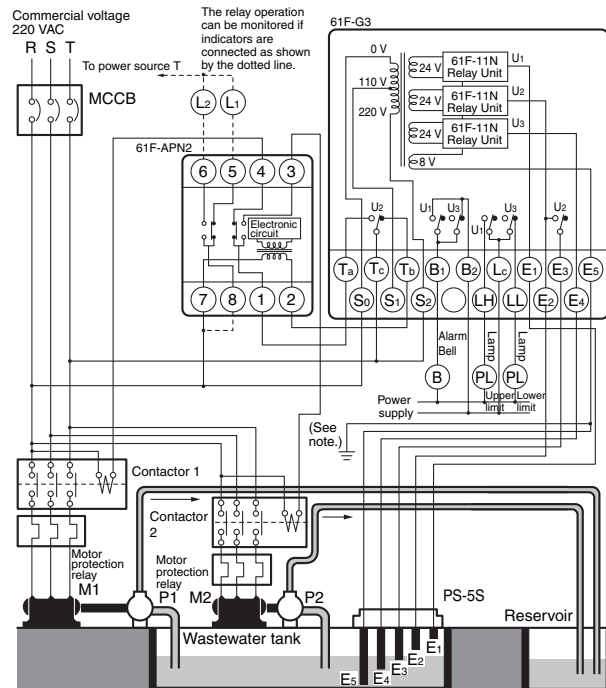

Note: Be sure to ground the common Electrode E3 (the longest Electrode).

Combining with the 61F-G4N

Alternate Operation Relay 61F-AN

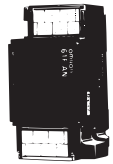

Dimensions:
page 17

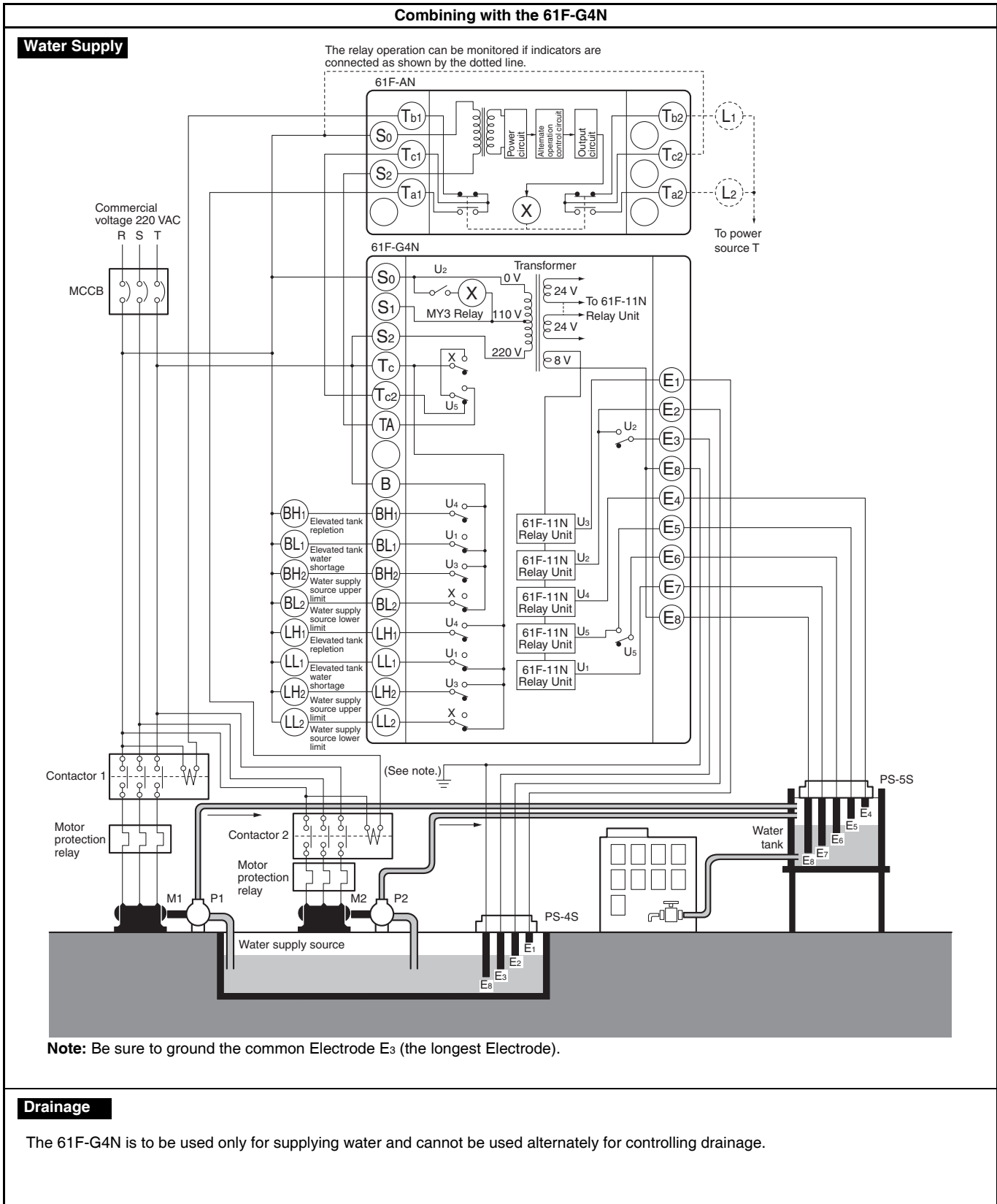

Combining with the 61F-G4

Alternate Operation Relay
61F-APN2

Dimensions:
page 17

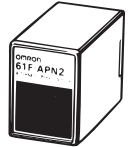

Combining with the 61F-G4

Water Supply

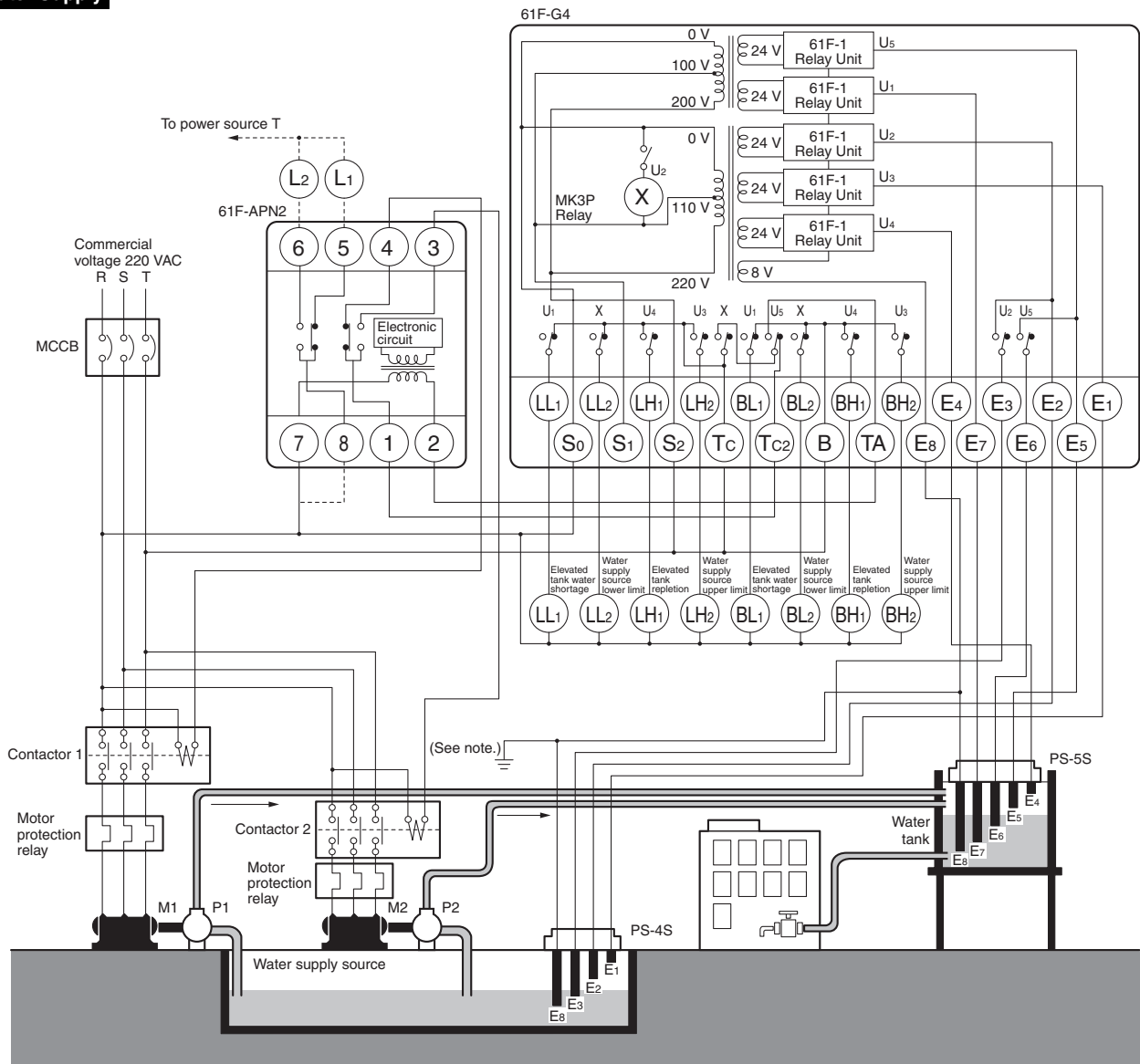

Note: Be sure to ground the common Electrode E₃ (the longest Electrode).

Drainage

The 61F-G4N is to be used only for supplying water and cannot be used alternately for controlling drainage.

At 220 VAC

Water Supply (When Combined with 61F-G1P)

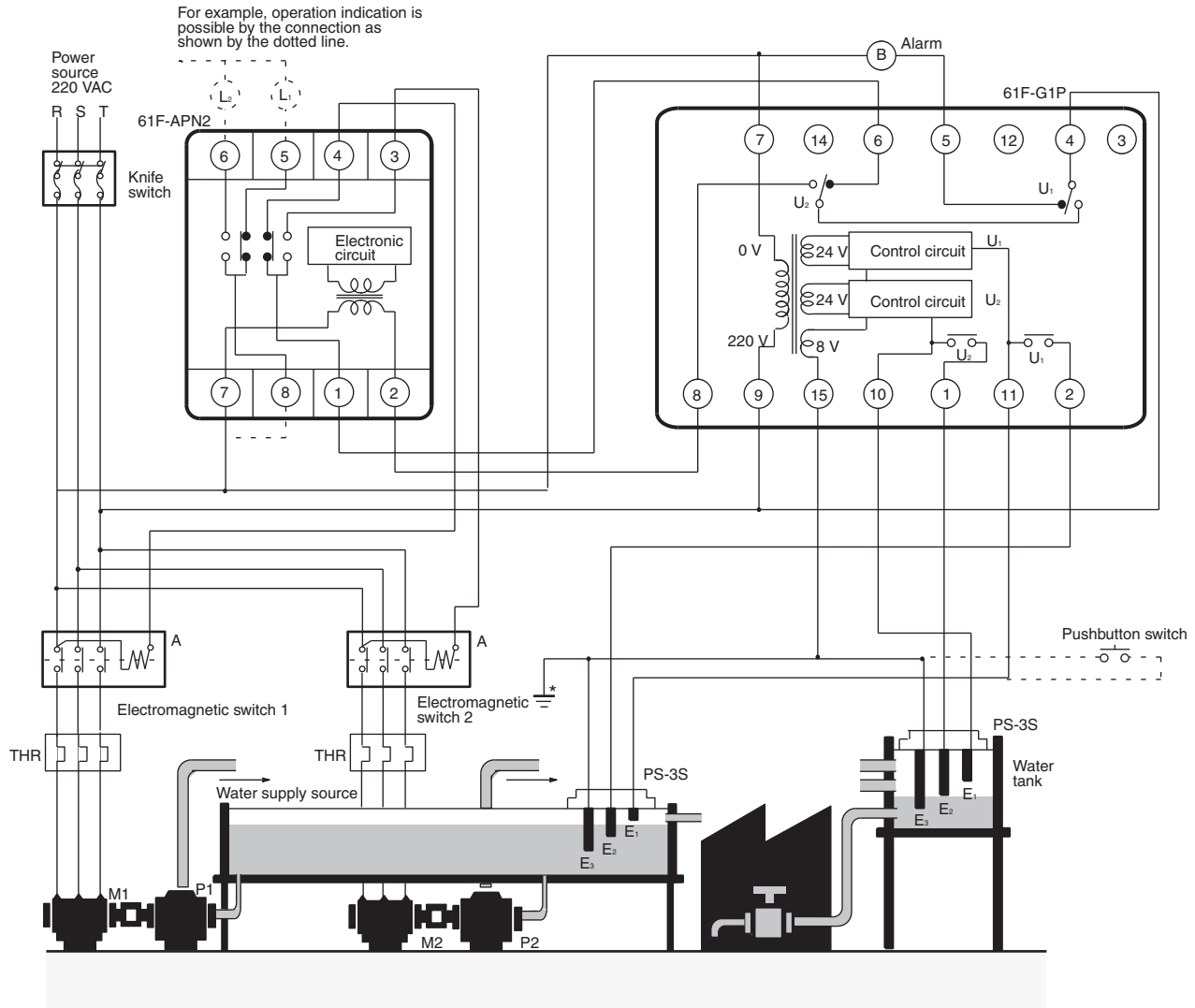

*Be sure to ground terminal 15.

Water Supply (When Combined with 61F-GP-N)

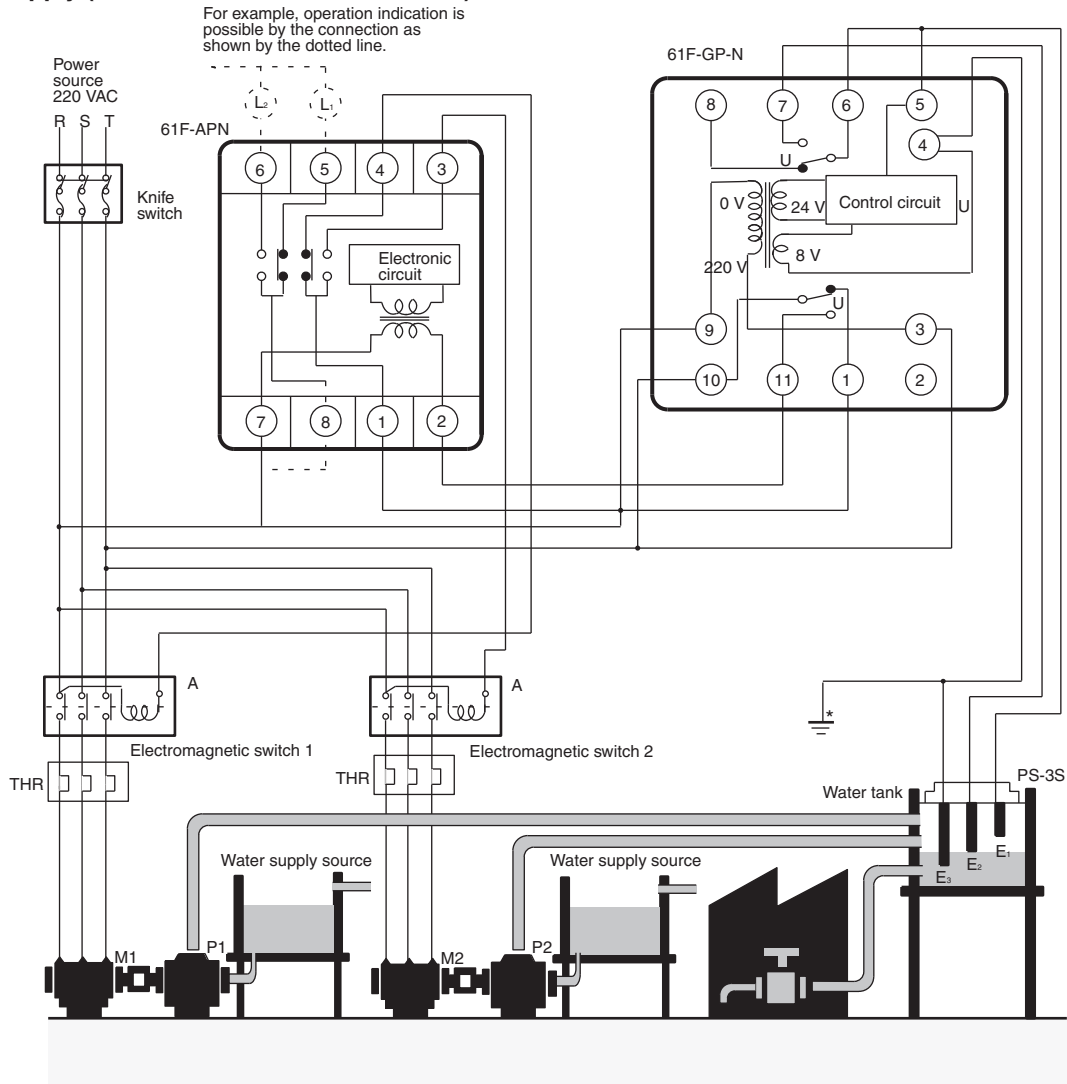

*Be sure to ground terminal 4.

Water Drainage (When Combined with 61F-G2P)

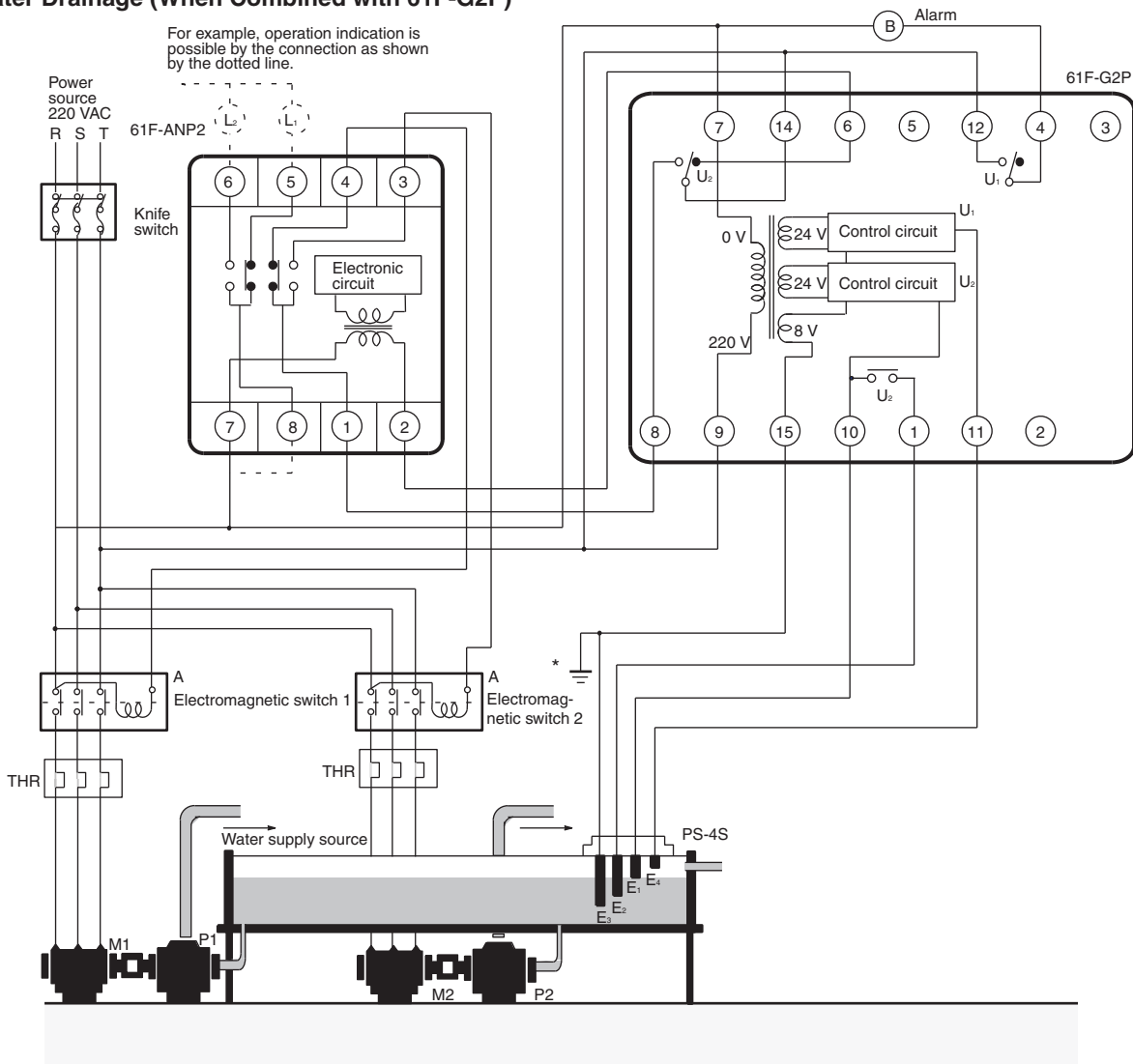

*Be sure to ground terminal 15.

Dimensions

Note: All units are in millimeters unless otherwise indicated.

61F-AN

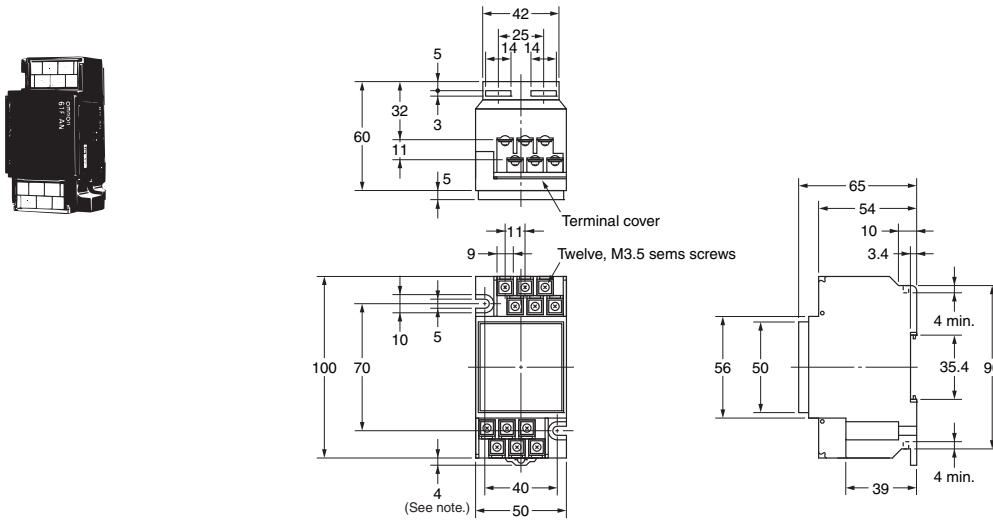

Note: Dimensions are with the DIN rail mounting (sliding) bracket attached.

61F-APN2

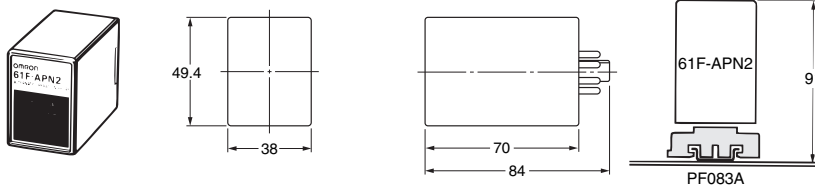

Use a PFC-N8 Mounting Bracket to mount the Level Controller to a PF083A Rail-mounted Socket.

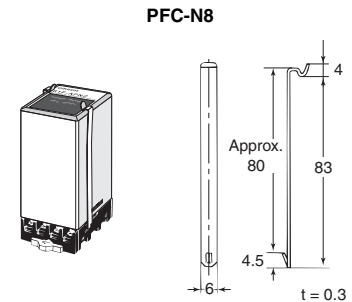

Note: PFC-N8 Mounting Bracket (provided with the Level Controller)

■ Safety Precautions

Refer to *Safety Precautions for All Level Controllers*.

ALL DIMENSIONS SHOWN ARE IN MILLIMETERS.
To convert millimeters into inches, multiply by 0.03937. To convert grams into ounces, multiply by 0.03527.

In the interest of product improvement, specifications are subject to change without notice.

Terms and Conditions Agreement

Read and understand this catalog.

Please read and understand this catalog before purchasing the products. Please consult your OMRON representative if you have any questions or comments.

Warranties.

(a) Exclusive Warranty. Omron's exclusive warranty is that the Products will be free from defects in materials and workmanship for a period of twelve months from the date of sale by Omron (or such other period expressed in writing by Omron). Omron disclaims all other warranties, express or implied.

(b) Limitations. OMRON MAKES NO WARRANTY OR REPRESENTATION, EXPRESS OR IMPLIED, ABOUT NON-INFRINGEMENT, MERCHANTABILITY OR FITNESS FOR A PARTICULAR PURPOSE OF THE PRODUCTS. BUYER ACKNOWLEDGES THAT IT ALONE HAS DETERMINED THAT THE PRODUCTS WILL SUITABLY MEET THE REQUIREMENTS OF THEIR INTENDED USE.

Omron further disclaims all warranties and responsibility of any type for claims or expenses based on infringement by the Products or otherwise of any intellectual property right. (c) Buyer Remedy. Omron's sole obligation hereunder shall be, at Omron's election, to (i) replace (in the form originally shipped with Buyer responsible for labor charges for removal or replacement thereof) the non-complying Product, (ii) repair the non-complying Product, or (iii) repay or credit Buyer an amount equal to the purchase price of the non-complying Product; provided that in no event shall Omron be responsible for warranty, repair, indemnity or any other claims or expenses regarding the Products unless Omron's analysis confirms that the Products were properly handled, stored, installed and maintained and not subject to contamination, abuse, misuse or inappropriate modification. Return of any Products by Buyer must be approved in writing by Omron before shipment. Omron Companies shall not be liable for the suitability or unsuitability or the results from the use of Products in combination with any electrical or electronic components, circuits, system assemblies or any other materials or substances or environments. Any advice, recommendations or information given orally or in writing, are not to be construed as an amendment or addition to the above warranty.

See <http://www.omron.com/global/> or contact your Omron representative for published information.

Limitation on Liability: Etc.

OMRON COMPANIES SHALL NOT BE LIABLE FOR SPECIAL, INDIRECT, INCIDENTAL, OR CONSEQUENTIAL DAMAGES, LOSS OF PROFITS OR PRODUCTION OR COMMERCIAL LOSS IN ANY WAY CONNECTED WITH THE PRODUCTS, WHETHER SUCH CLAIM IS BASED IN CONTRACT, WARRANTY, NEGLIGENCE OR STRICT LIABILITY.

Further, in no event shall liability of Omron Companies exceed the individual price of the Product on which liability is asserted.

Suitability of Use.

Omron Companies shall not be responsible for conformity with any standards, codes or regulations which apply to the combination of the Product in the Buyer's application or use of the Product. At Buyer's request, Omron will provide applicable third party certification documents identifying ratings and limitations of use which apply to the Product. This information by itself is not sufficient for a complete determination of the suitability of the Product in combination with the end product, machine, system, or other application or use. Buyer shall be solely responsible for determining appropriateness of the particular Product with respect to Buyer's application, product or system. Buyer shall take application responsibility in all cases.

NEVER USE THE PRODUCT FOR AN APPLICATION INVOLVING SERIOUS RISK TO LIFE OR PROPERTY OR IN LARGE QUANTITIES WITHOUT ENSURING THAT THE SYSTEM AS A WHOLE HAS BEEN DESIGNED TO ADDRESS THE RISKS, AND THAT THE OMRON PRODUCT(S) IS PROPERLY RATED AND INSTALLED FOR THE INTENDED USE WITHIN THE OVERALL EQUIPMENT OR SYSTEM.

Programmable Products.

Omron Companies shall not be responsible for the user's programming of a programmable Product, or any consequence thereof.

Performance Data.

Data presented in Omron Company websites, catalogs and other materials is provided as a guide for the user in determining suitability and does not constitute a warranty. It may represent the result of Omron's test conditions, and the user must correlate it to actual application requirements. Actual performance is subject to the Omron's Warranty and Limitations of Liability.

Change in Specifications.

Product specifications and accessories may be changed at any time based on improvements and other reasons. It is our practice to change part numbers when published ratings or features are changed, or when significant construction changes are made. However, some specifications of the Product may be changed without any notice. When in doubt, special part numbers may be assigned to fix or establish key specifications for your application. Please consult with your Omron's representative at any time to confirm actual specifications of purchased Product.

Errors and Omissions.

Information presented by Omron Companies has been checked and is believed to be accurate; however, no responsibility is assumed for clerical, typographical or proofreading errors or omissions.