



±15kV ESD-Protected, Low-Voltage, Dual, SPST, CMOS Analog Switches

MAX4575/MAX4576/MAX4577

General Description

The MAX4575/MAX4576/MAX4577 are low-voltage, high electrostatic discharge (ESD)-protected, dual single-pole/single-throw (SPST) analog switches. The normally closed (NO) and normally open (NC) pins are protected against ±15kV ESD without latchup or damage. Each switch can handle Rail-to-Rail® analog signals. Off-leakage current is 0.5nA at +25°C. These analog switches are suitable for low-distortion audio applications and are the preferred solution over mechanical relays in automated test equipment or applications where current switching is required. They have low power requirements (0.5µW), require less board space, and are more reliable than mechanical relays. Each device is controlled by TTL/CMOS input voltage levels and is bilateral.

These switches feature guaranteed operation from a single supply of +2V to +12V, making them ideal for use in battery-powered applications. On-resistance is 70Ω (max), matched between switches to 0.5Ω (typ) and flat (2Ω typ) over the specified signal range.

The MAX4575 has two NO switches, the MAX4576 has two NC switches, and the MAX4577 has one NO and one NC switch. These devices are available in 8-pin µMAX and SO packages.

Applications

- Battery-Powered Systems
- Audio and Video Signal Routing
- Low-Voltage Data-Acquisition Systems
- Sample-and-Hold Circuits
- Communications Circuits
- Relay Replacement

Ordering Information

PART	TEMP. RANGE	PIN-PACKAGE
MAX4575 EUA	-40°C to +85°C	8 µMAX
MAX4575ESA	-40°C to +85°C	8 SO
MAX4576 EUA	-40°C to +85°C	8 µMAX
MAX4576ESA	-40°C to +85°C	8 SO
MAX4577 EUA	-40°C to +85°C	8 µMAX
MAX4577ESA	-40°C to +85°C	8 SO

Rail-to-Rail is a registered trademark of Nippon Motorola, Ltd.

Features

- ◆ ESD-Protected NO/NC Pins
 - ±15kV (Human Body Model)
 - ±15kV (IEC 1000-4-2 Air-Gap Discharge)
 - ±8kV (IEC 1000-4-2 Contact Discharge)
- ◆ Pin Compatible with MAX4541/MAX4542/MAX4543
- ◆ Guaranteed On-Resistance
 - 70Ω (max) at +5V
 - 150Ω (max) at +3V
- ◆ On-Resistance Flatness
 - 2Ω (typ) at +5V
 - 6Ω (typ) at +3V
- ◆ On-Resistance Matching
 - 0.5Ω (typ) at +5V
 - 0.6Ω (typ) at +3V
- ◆ Guaranteed 0.5nA Leakage Current at T_A = +25°C
- ◆ +2V to +12V Single-Supply Voltage
- ◆ TTL/CMOS-Logic Compatible
- ◆ Low Distortion: 0.015%
- ◆ -3dB Bandwidth >300MHz
- ◆ Rail-to-Rail Signal Range

Pin Configurations/ Functional Diagrams/Truth Tables

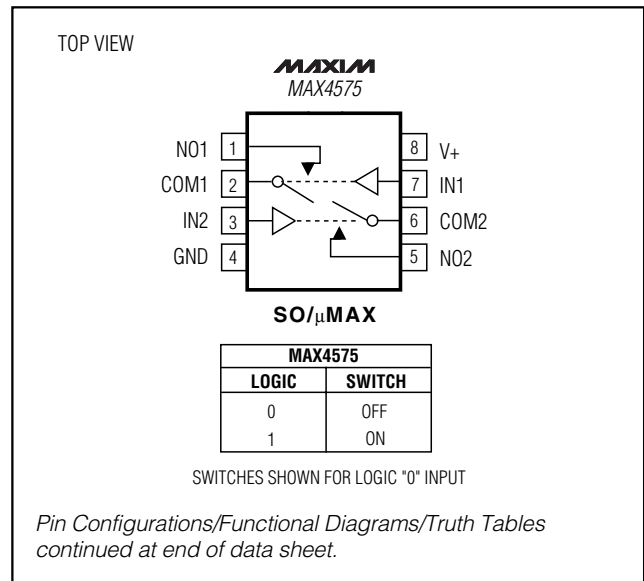

±15kV ESD-Protected, Low-Voltage, Dual, SPST, CMOS Analog Switches

ABSOLUTE MAXIMUM RATINGS

V+ to GND	-0.3V to +13V
IN ₋ , COM ₋ , NO ₋ , NC ₋ to GND (Note 1)	-0.3V to (V+ + 0.3V)
Continuous Current (NO ₋ , NC ₋ , COM ₋)	±10mA
Peak Current (NO ₋ , NC ₋ , COM ₋ ; pulsed at 1ms 10% duty cycle)	±30mA
ESD Protection per Method IEC 1000-4-2 (NO ₋ , NC ₋)	
Air-Gap Discharge	±15kV
Contact Discharge	±8kV
ESD Protection per Method 3015.7	
NO ₋ , NC ₋	±15kV
V+, GND, IN ₋ , COM ₋	±2.5kV

Continuous Power Dissipation (T _A = +70°C)	
8-Pin μMAX (derate 4.1mW/°C above +70°C)	330mW
8-Pin SO (derate 8mW/°C above +70°C)	640mW
Operating Temperature Range	
MAX457_E_A	-40°C to +85°C
Storage Temperature Range	-65°C to +150°C
Maximum Die Temperature	+150°C
Lead Temperature (soldering, 10s)	+300°C

Note 1: Signals on NO₋, NC₋, COM₋, or IN₋ exceeding V+ or GND are clamped by internal diodes. Limit forward current to maximum current rating.

Stresses beyond those listed under "Absolute Maximum Ratings" may cause permanent damage to the device. These are stress ratings only, and functional operation of the device at these or any other conditions beyond those indicated in the operational sections of the specifications is not implied. Exposure to absolute maximum rating conditions for extended periods may affect device reliability.

ELECTRICAL CHARACTERISTICS—SINGLE +5V SUPPLY

(V+ = +4.5V to +5.5V, V_{IH} = 2.4V, V_{IL} = 0.8V, T_A = T_{MIN} to T_{MAX}, unless otherwise specified. Typical values are at V+ = +5V, T_A = +25°C.) (Note 2)

PARAMETER	SYMBOL	CONDITIONS	MIN	TYP	MAX	UNITS	
ANALOG SWITCH							
Input Voltage Range	V _{COM-} , V _{NO-} , V _{NC-}		0		V+	V	
On-Resistance	R _{ON}	V+ = +4.5V, I _{COM-} = 1mA, V _{NO-} or V _{NC-} = 3.5V	T _A = +25°C	45	70	Ω	
			T _A = T _{MIN} to T _{MAX}		75		
On-Resistance Match Between Channels (Note 3)	ΔR _{ON}	V+ = +4.5V, I _{COM-} = 1mA, V _{NO-} or V _{NC-} = 3.5V	T _A = +25°C	0.5	2	Ω	
			T _A = T _{MIN} to T _{MAX}		3		
On-Resistance Flatness (Note 4)	R _{FLAT(ON)}	V+ = +4.5V, I _{COM-} = 1mA, V _{NO-} or V _{NC-} = 1V, 2.25V, 3.5V	T _A = +25°C	2	4	Ω	
			T _A = T _{MIN} to T _{MAX}		5		
Off-Leakage Current (NO ₋ or NC ₋) (Note 5)	I _{NO-} , I _{NC-}	V+ = 5.5V V _{COM-} = 1V, 4.5V V _{NO-} or V _{NC-} = 4.5V, 1V	T _A = +25°C	-0.5	0.01	0.5	nA
			T _A = T _{MIN} to T _{MAX}	-5		5	
COM ₋ Off-Leakage Current (Note 5)	I _{COM-(OFF)}	V+ = 5.5V V _{COM-} = 1V, 4.5V V _{NO-} or V _{NC-} = 4.5V, 1V	T _A = +25°C	-0.5	0.01	0.5	nA
			T _A = T _{MIN} to T _{MAX}	-5		5	
COM ₋ On-Leakage Current (Note 5)	I _{COM-(ON)}	V+ = 5.5V V _{COM-} = 1V, 4.5V V _{NO-} or V _{NC-} = 1V, 4.5V or floating	T _A = +25°C	-1	0.02	1	nA
			T _A = T _{MIN} to T _{MAX}	-10		10	

±15kV ESD-Protected, Low-Voltage, Dual, SPST, CMOS Analog Switches

MAX4575/MAX4576/MAX4577

ELECTRICAL CHARACTERISTICS—SINGLE +5V SUPPLY (continued)

(V+ = +4.5V to +5.5V, V_{IH} = 2.4V, V_{IL} = 0.8V, T_A = T_{MIN} to T_{MAX}, unless otherwise specified. Typical values are at V+ = +5V, T_A = +25°C.) (Note 2)

PARAMETER	SYMBOL	CONDITIONS	MIN	TYP	MAX	UNITS
LOGIC INPUT						
IN_ Input High	V _{IH}		2.4			V
IN_ Input Low	V _{IL}				0.8	V
Logic Input Leakage	I _{IN}	V _{IN} = 0 or V+	-1		1	μA
SWITCH DYNAMIC						
Turn-On Time	t _{ON}	V _{COM_} = 3V, R _L = 300Ω, C _L = 35pF, Figure 1	T _A = +25°C	90	150	ns
			T _A = T _{MIN} to T _{MAX}			
Turn-Off Time	t _{OFF}	V _{COM_} = 3V, R _L = 300Ω, C _L = 35pF, Figure 1	T _A = +25°C	50	80	ns
			T _A = T _{MIN} to T _{MAX}			
Break-Before-Make (MAX4577 only)		V _{COM_} = 3V, R _L = 300Ω, C _L = 35pF	T _A = +25°C	5	45	ns
			T _A = T _{MIN} to T _{MAX}	4		
On-Channel Bandwidth -3dB	BW	Signal = 0dBm, R _{IN} = R _{OUT} = 50Ω, C _L = 5pF, Figure 2		300		MHz
Charge Injection	Q	V _{GEN} = 2V, C _L = 1.0nF, R _{GEN} = 0, Figure 3		4		pC
NO_ or NC_ Off-Capacitance	C _{OFF}	V _{NO_} = V _{NC_} = GND, f = 1MHz, Figure 4		20		pF
COM_ Off-Capacitance	C _{COM(OFF)}	V _{COM_} = GND, f = 1MHz, Figure 4		12		pF
COM_ On-Capacitance	C _{COM(ON)}	V _{COM_} = V _{NO_} , V _{NC_} = GND, f = 1MHz,		20		pF
Off-Isolation (Note 7)	V _{ISO}	R _L = 50Ω, C _L = 5pF, f = 1MHz, Figure 2		-75		dB
		R _L = 50Ω, C _L = 5pF, f = 10MHz, Figure 2		-45		
Crosstalk (Note 8)	V _{CT}	R _L = 50Ω, C _L = 5pF, f = 1MHz, Figure 6		-90		dB
		R _L = 50Ω, C _L = 5pF, f = 10MHz, Figure 6		-70		
Total Harmonic Distortion	THD	R _L = 600Ω, f = 20Hz to 20kHz		0.015		%
ESD SCR Holding Current	I _H			110		mA
ESD SCR Holding Voltage	V _H			3		V
POWER SUPPLY						
Power-Supply Range	V+		2		12	V
Positive Supply Current	I+	V+ = 5.5V, V _{IN} = 0 or V+	T _A = +25°C		1	μA
			T _A = T _{MIN} to T _{MAX}			

±15kV ESD-Protected, Low-Voltage, Dual, SPST, CMOS Analog Switches

ELECTRICAL CHARACTERISTICS—SINGLE +3V SUPPLY

(V+ = +2.7V to +3.6V, V_{IH} = 2.0V, V_{IL} = 0.6V, T_A = T_{MIN} to T_{MAX}, unless otherwise specified. Typical values are at T_A = +25°C.) (Note 2)

PARAMETER	SYMBOL	CONDITIONS	MIN	TYP	MAX	UNITS
ANALOG SWITCH						
Input Voltage Range	V _{COM_} , V _{NO_} , V _{NC_}		0		V+	V
On-Resistance	R _{ON}	V+ = 2.7V; I _{COM_} = 1mA; V _{NO_} or V _{NC_} = 1.5V	T _A = +25°C	70	120	Ω
			T _A = T _{MIN} to T _{MAX}		150	
On-Resistance Match Between Channels (Notes 3, 8)	ΔR _{ON}	V+ = 2.7V; I _{COM_} = 1mA; V _{NO_} or V _{NC_} = 1.5V	T _A = +25°C	0.6	3	Ω
			T _A = T _{MIN} to T _{MAX}		4	
On-Resistance Flatness (Notes 4, 8)	R _{FLAT(ON)}	V+ = 2.7V; I _{COM_} = 1mA; V _{NO_} or V _{NC_} = 0.5V, 1.5V, 2.2V	T _A = +25°C	6	12	Ω
			T _A = T _{MIN} to T _{MAX}		15	
LOGIC INPUT						
IN_ Input High	V _{IH}		2.0			V
IN_ Input Low	V _{IL}				0.6	V
Logic Input Leakage Current	I _{IN}	V _{IN} = 0 or V+	-1		1	μA
SWITCH DYNAMIC CHARACTERISTICS						
Turn-On Time	t _{ON}	V _{COM_} = 1.5V, R _L = 300Ω, C _L = 35pF, Figure 1	T _A = +25°C	150	250	ns
			T _A = T _{MIN} to T _{MAX}		300	
Turn-Off Time	t _{OFF}	V _{COM_} = 1.5V, R _L = 300Ω, C _L = 35pF, Figure 1	T _A = +25°C	60	100	ns
			T _A = T _{MIN} to T _{MAX}		150	
Break-Before-Make (MAX4577 only)		V _{COM_} = 1.5V, R _L = 300Ω, C _L = 35pF	T _A = +25°C	5		ns
			T _A = T _{MIN} to T _{MAX}	4		
Charge Injection	Q	V _{GEN} = 1.5V, C _L = 1.0nF, R _{GEN} = 0, Figure 3		5		pC
ESD SCR Holding Current	I _H			110		mA
ESD SCR Holding Voltage	V _H			3		V
POWER SUPPLY						
Power-Supply Range	V+		2		12	V
Positive Supply Current	I+	V+ = 3.6V, V _{IN} = 0 or V+	T _A = +25°C		1	μA
			T _A = T _{MIN} to T _{MAX}		10	

Note 2: The algebraic convention, where the most negative value is a minimum and the most positive value is a maximum, is used in this data sheet.

Note 3: ΔR_{ON} = R_{ON(MAX)} - R_{ON(MIN)}.

Note 4: Flatness is defined as the difference between the maximum and the minimum values of on-resistance as measured over the specified analog signal ranges.

Note 5: Leakage parameters are 100% tested at T_{A(MAX)}, and guaranteed by correlation at +25°C.

Note 6: Off-Isolation = 20log₁₀(V_{COM} / V_{NO}), V_{COM} = output, V_{NO} = input to off switch.

Note 7: Between any two switches.

Note 8: Guaranteed by design.

±15kV ESD-Protected, Low-Voltage, Dual, SPST, CMOS Analog Switches

Typical Operating Characteristics

($V_+ = 5V$, $T_A = +25^\circ\text{C}$, unless otherwise specified.)

MAX4575/MAX4576/MAX4577

ON-RESISTANCE vs. V_{COM} AND SUPPLY VOLTAGE

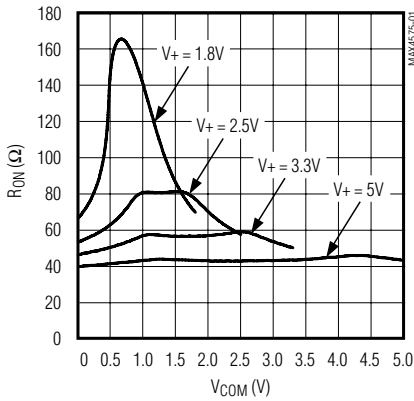

ON-RESISTANCE vs. V_{COM} AND TEMPERATURE

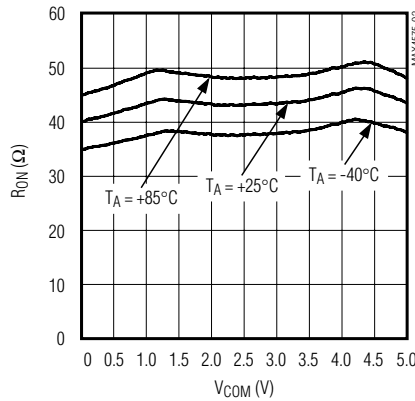

ON/OFF-LEAKAGE CURRENT vs. TEMPERATURE

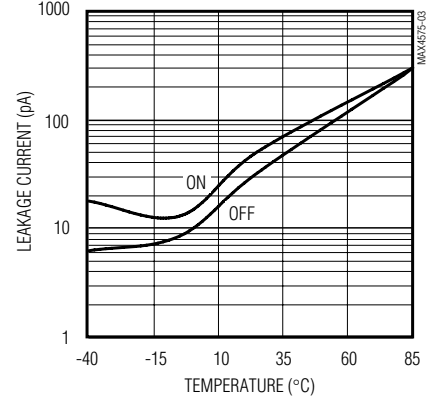

SUPPLY CURRENT vs. V_{CC} AND TEMPERATURE

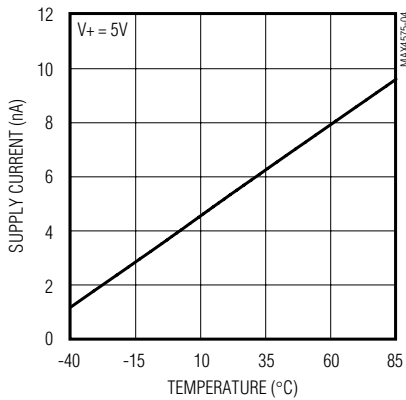

TURN-ON/TURN-OFF TIME vs. TEMPERATURE

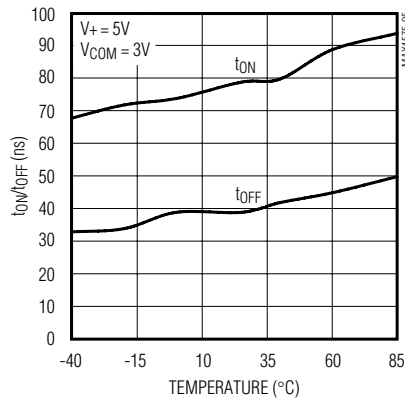

TURN-ON/TURN-OFF TIME vs. SUPPLY VOLTAGE

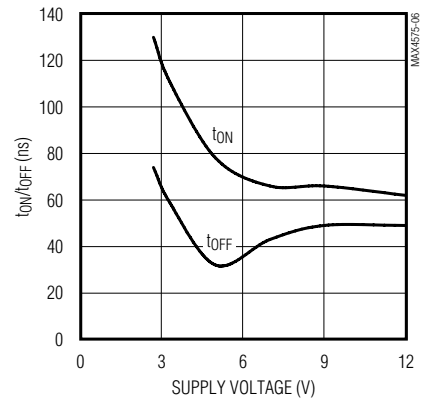

TURN-ON/TURN-OFF TIME vs. V_{COM} ($V_+ = 3V$)

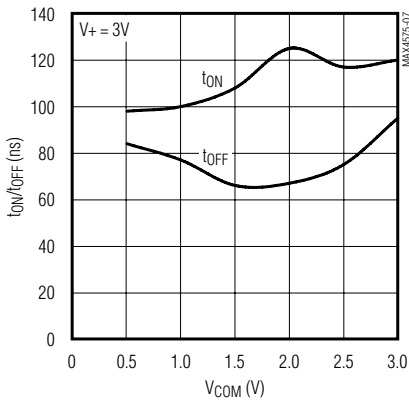

TURN-ON/TURN-OFF vs. V_{COM} ($V_+ = 5V$)

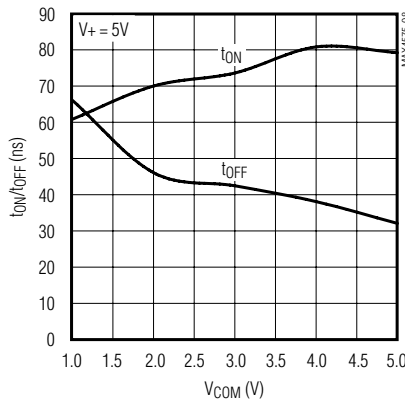

CHARGE INJECTION vs. V_{COM}

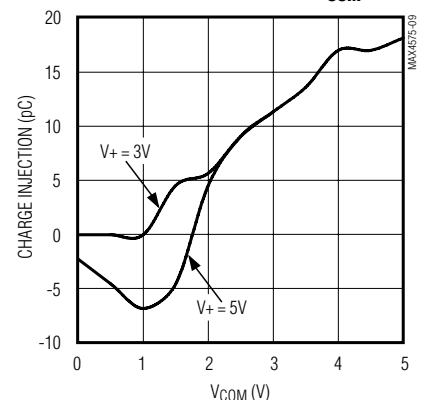

±15kV ESD-Protected, Low-Voltage, Dual, SPST, CMOS Analog Switches

Typical Operating Characteristics (continued)

(V+ = 5V, TA = +25°C, unless otherwise specified.)

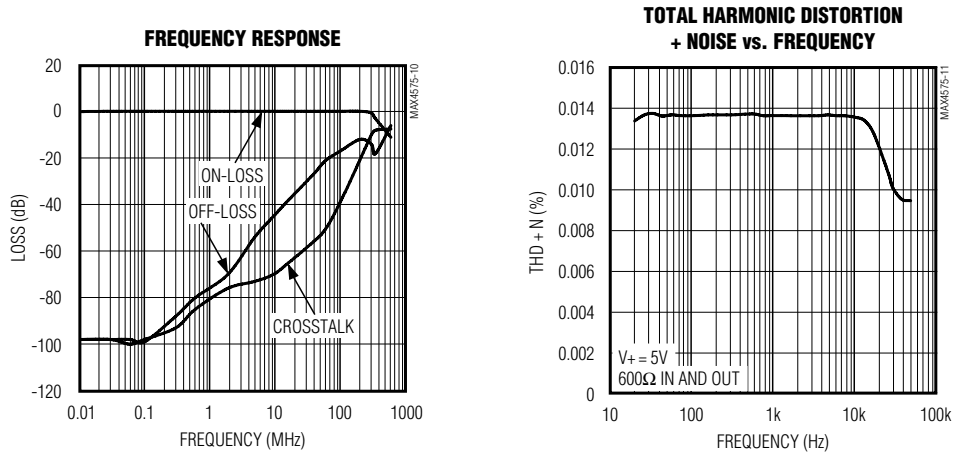

Pin Description

PIN			NAME	FUNCTION
MAX4575	MAX4576	MAX4577		
1	—	1	NO1	Analog Switch 1—Normally Open
—	1	—	NC1	Analog Switch 1—Normally Closed
2	2	2	COM1	Analog Switch 1—Common
3	3	3	IN2	Digital Control Input 2
4	4	4	GND	Ground
5	—	—	NO2	Analog Switch 2—Normally Open
—	5	5	NC2	Analog Switch 2—Normally Closed
6	6	6	COM2	Analog Switch 2—Common
7	7	7	IN1	Digital Control Input 1
8	8	8	V+	Positive Supply Voltage Input

±15kV ESD-Protected, Low-Voltage, Dual, SPST, CMOS Analog Switches

MAX4575/MAX4576/MAX4577

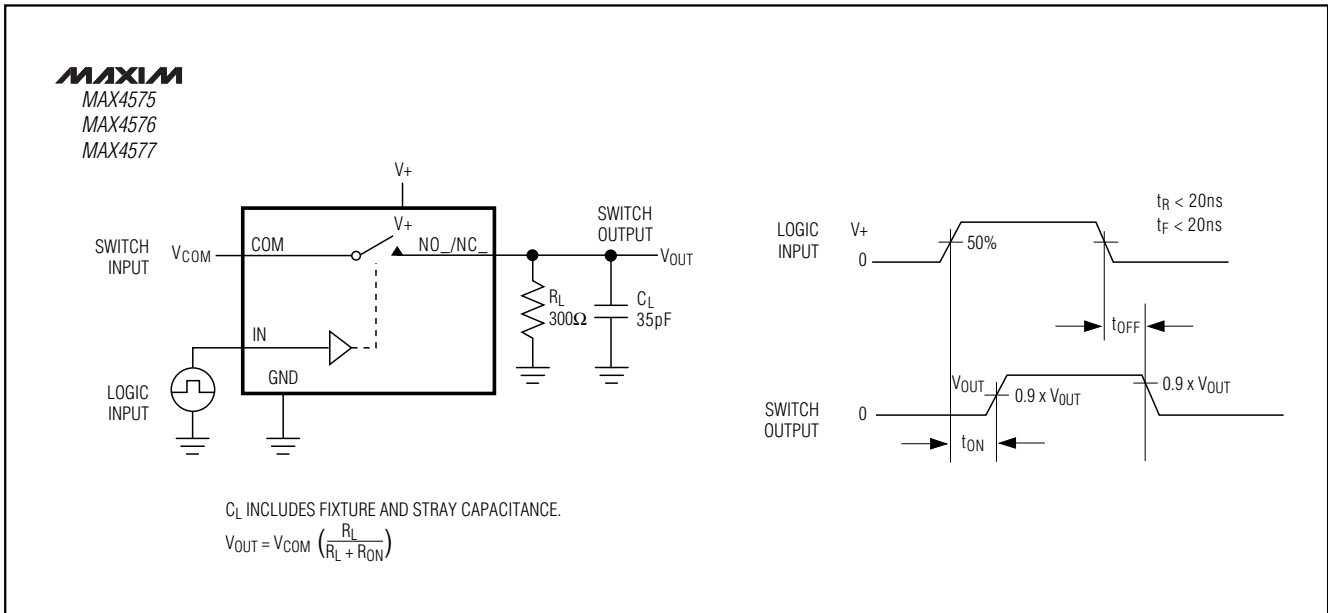

Figure 1. Switching Time

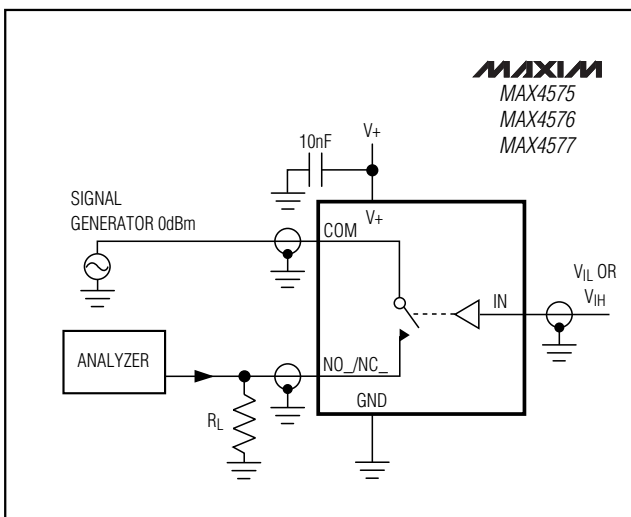

Figure 2. Off-Isolation/On-Channel Bandwidth

Detailed Description

The MAX4575/MAX4576/MAX4577 are dual SPST CMOS analog switches with circuitry providing ±15kV ESD protection on the NO and NC pins. The CMOS switch construction provides rail-to-rail signal handling while consuming virtually no power. Each of the two

switches is independently controlled by a TTL/CMOS-level-compatible digital input.

Applications Information

Do not exceed the absolute maximum ratings because stresses beyond the listed ratings may cause permanent damage to the device.

Proper power-supply sequencing is recommended for all CMOS devices. Always sequence V+ on first, followed by the logic inputs, NO/NC, or COM.

Operating Considerations for High-Voltage Supply

The MAX4575/MAX4576/MAX4577 are capable of +12V single-supply operation with some precautions. The absolute maximum rating for V+ is +13V (referenced to GND). When operating near this region, bypass V+ with a minimum 0.1μF capacitor to ground as close to the IC as possible.

±15kV ESD Protection

The MAX4575/MAX4576/MAX4577 are ±15kV ESD protected (according to IEC 1000-4-2) at the NC/NO terminals. To accomplish this, bidirectional SCRs are included on-chip between these terminals. When the voltages at these terminals go Beyond-the-Rail™, the corresponding SCRs turns on in a few nanoseconds

Beyond-the-Rail is a trademark of Maxim Integrated Products.

±15kV ESD-Protected, Low-Voltage, Dual, SPST, CMOS Analog Switches

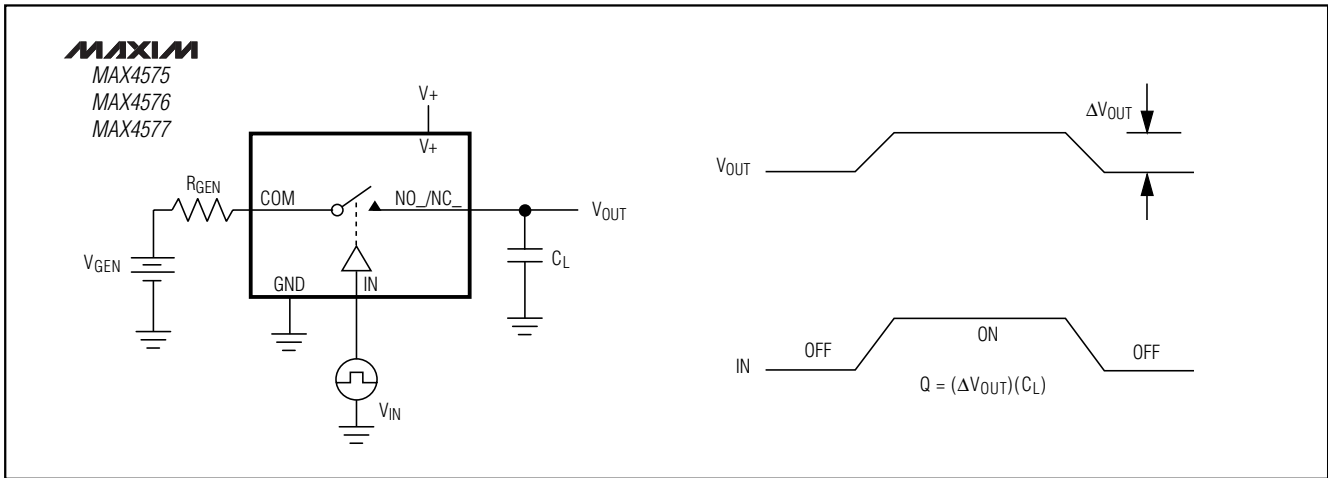

Figure 3. Charge Injection

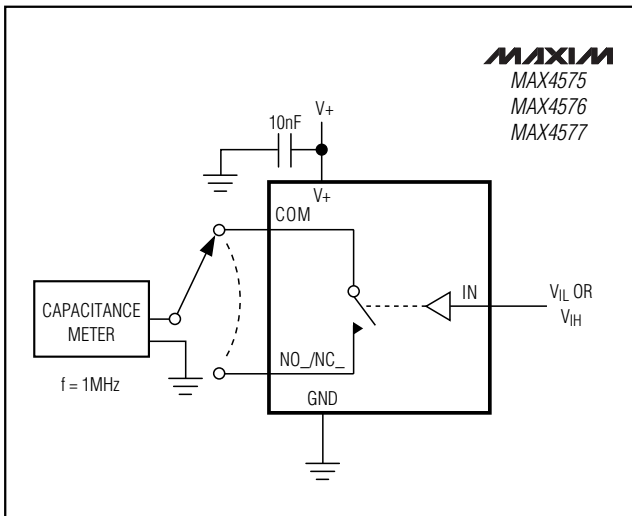

Figure 4. Channel Off/On-Capacitance

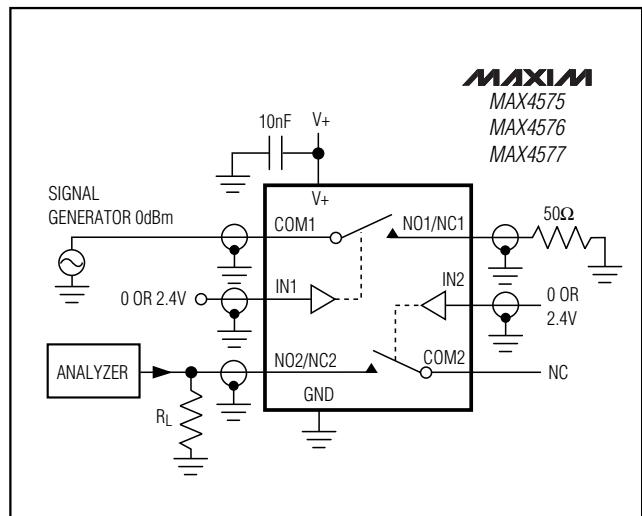

Figure 5. Crosstalk

and bypass the surge safely to ground. This method is superior to using diode clamps to the supplies because, unless the supplies are very carefully decoupled through low-ESR capacitors, the ESD current through the diode clamp could cause a significant spike in the supplies. This may damage or compromise the reliability of any other chip powered by those same supplies.

There are diodes from NC/NO to the supplies in addition to the SCRs. There is a resistance in series with each of these diodes to limit the current into the supplies during an ESD strike. The diodes protect these

terminals from overvoltages that are not a result of ESD strikes. These diodes also protect the device from improper power-supply sequencing.

Once the SCR turns on because of an ESD strike, it continues to be on until the current through it falls below its “holding current.” The holding current is typically 110mA in the positive direction (current flowing into the NC/NO terminal) at room temperature (see SCR Holding Current vs. Temperature in the *Typical Operating Characteristics*). Design the system so that any sources connected to NC/NO are current limited to a value below the holding current to ensure the SCR

±15kV ESD-Protected, Low-Voltage, Dual, SPST, CMOS Analog Switches

turns off when the ESD event is finished and normal operation may be resumed. Also, keep in mind that the holding current varies significantly with temperature. The worst case is at +85°C when the holding currents drop to 70mA. Since this is a typical number to guarantee turn-off of the SCRs under all conditions, the sources connected to these terminals should be current limited to not more than half this value. When the SCR is latched, the voltage across it is about 3V, depending on the polarity of the pin current. The supply voltages do not affect the holding current appreciably. The sources connected to the COM side of the switches do not need to be current limited since the switches turn off internally when the corresponding SCR(s) latches.

Even though most of the ESD current flows to GND through the SCRs, a small portion of it goes into V+. Therefore, it is a good idea to bypass the V+ with 0.1µF capacitors directly to the ground plane.

ESD protection can be tested in various ways. Transmitter outputs and receiver inputs are characterized for protection to the following:

- ±15kV using the Human Body Model
- ±8kV using the Contact Discharge method specified in IEC 1000-4-2 (formerly IEC 801-2)
- ±15kV using the Air-Gap Discharge method specified in IEC 1000-4-2 (formerly IEC 801-2).

ESD Test Conditions

Contact Maxim Integrated Products for a reliability report that documents test setup, methodology, and results.

Human Body Model

Figure 6 shows the Human Body Model and Figure 7 shows the waveform it generates when discharged into a low impedance. This model consists of a 100pF capacitor charged to the ESD voltage of interest, which can be discharged into the test device through a 1.5kΩ resistor.

IEC 1000-4-2

The IEC 1000-4-2 standard covers ESD testing and performance of finished equipment; it does not specifically refer to integrated circuits. The MAX4575/MAX4576/MAX4577 enable the design of equipment that meets Level 4 (the highest level) of IEC 1000-4-2, without additional ESD protection components.

The major difference between tests done using the Human Body Model and IEC 1000-4-2 is higher peak current in IEC 1000-4-2. Because series resistance is lower in the IEC 1000-4-2 ESD test model (Figure 8), the ESD withstand voltage measured to this standard is generally lower than that measured using the Human Body Model. Figure 9 shows the current waveform for the ±8kV IEC 1000-4-2 Level 4 ESD Contact Discharge test.

The Air-Gap test involves approaching the device with a charged probe. The Contact Discharge method connects the probe to the device before the probe is energized.

Chip Information

TRANSISTOR COUNT: 78

PROCESS: CMOS

MAX4575/MAX4576/MAX4577

±15kV ESD-Protected, Low-Voltage, Dual, SPST, CMOS Analog Switches

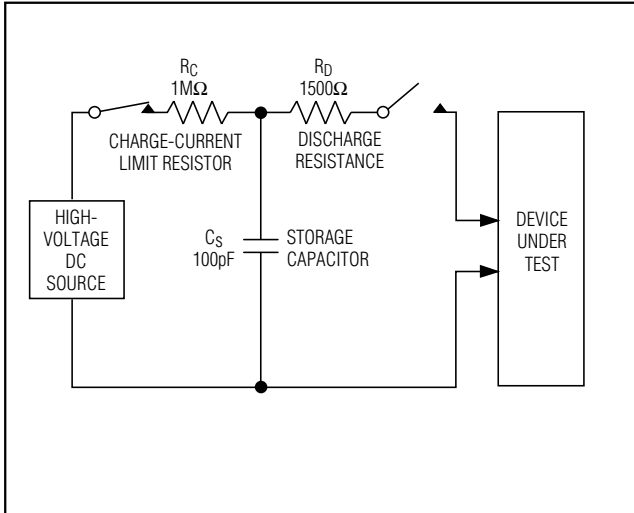

Figure 6. Human Body ESD Test Model

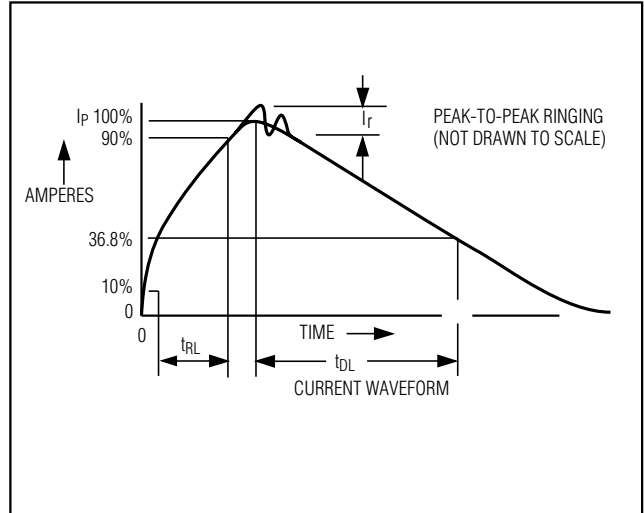

Figure 7. Human Body Model Current Waveform

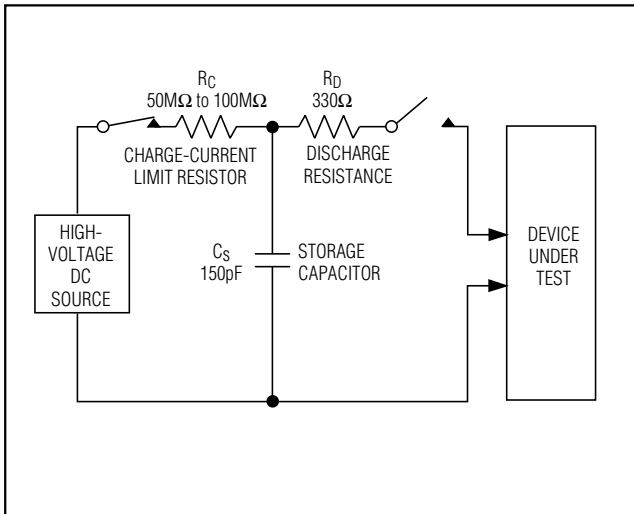

Figure 8. IEC 1000-4-2 ESD Test Model

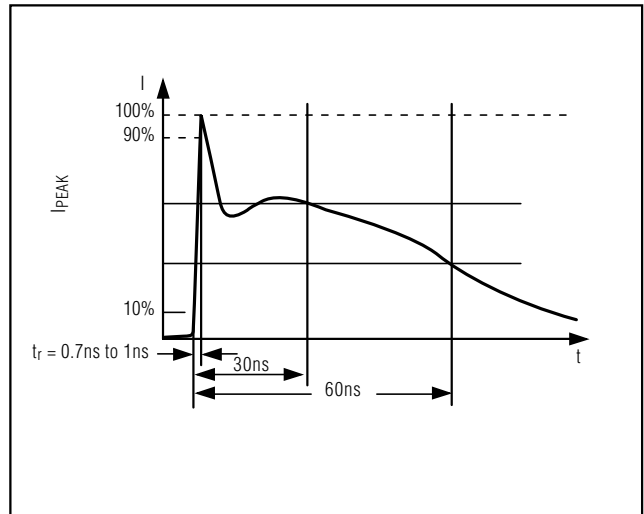

Figure 9. IEC 1000-4-2 ESD Generator Current Waveform

±15kV ESD-Protected, Low-Voltage, Dual, SPST, CMOS Analog Switches

Pin Configurations/Functional Diagrams/Truth Tables (continued)

TOP VIEW

MAX4576

SO/μMAX

MAX4576	
LOGIC	SWITCH
0	ON
1	OFF

MAX4577

SO/μMAX

MAX4577		
LOGIC	SWITCH 1	SWITCH 2
0	OFF	ON
1	ON	OFF

SWITCHES SHOWN FOR LOGIC "0" INPUT

MAX4575/MAX4576/MAX4577

Package Information

TOP VIEW

BOTTOM VIEW

		JEDEC					
		INCHES		MILLIMETERS			
		MIN	MAX	MIN	MAX		
A	0.037	0.043	0.94	1.10	---		
A1	0.002	0.006	0.05	0.15	0.002		
B	0.010	0.014	0.25	0.36	0.010		
C	0.005	0.007	0.13	0.18	0.005		
D	0.116	0.120	2.95	3.05	0.114		
e	0.0256	BSC		0.65	BSC		
E	0.116	0.120	2.95	3.05	0.114	0.122	
H	0.188	0.198	4.78	5.03	0.193	BSC	
L	0.016	0.026	0.41	0.66	0.016	0.027	0.40
α	0°	6°	0°	6°	0°	6°	0°
*X	0.087	0.099	2.210	2.515			
*Y	0.062	0.074	1.575	1.880			

* EXPOSED PAD (Note 5)

FRONT VIEW

SIDE VIEW

NOTES:

- D&E DO NOT INCLUDE MOLD FLASH.
- MOLD FLASH OR PROTRUSIONS NOT TO EXCEED .15 MM (.006").
- CONTROLLING DIMENSION: MILLIMETERS.
- MEETS JEDEC MO-187.
- DIMENSIONS X & Y APPLY TO EXPOSED PAD (EP) VERSIONS ONLY. SEE INDIVIDUAL PRODUCT DATASHEET TO DETERMINE IF A PRODUCT USES EXPOSED PAD PACKAGE.
- EXPOSED PAD FLUSH WITH BOTTOM OF PACKAGE WITHIN .002".

PROPRIETARY INFORMATION
TITLE: PACKAGE OUTLINE, 8L μMAX WITH EP OPTION
APPROVAL: _____ DOCUMENT CONTROL NO. 21-0036 REV H 1/1

±15kV ESD-Protected, Low-Voltage, Dual, SPST, CMOS Analog Switches

Package Information (continued)

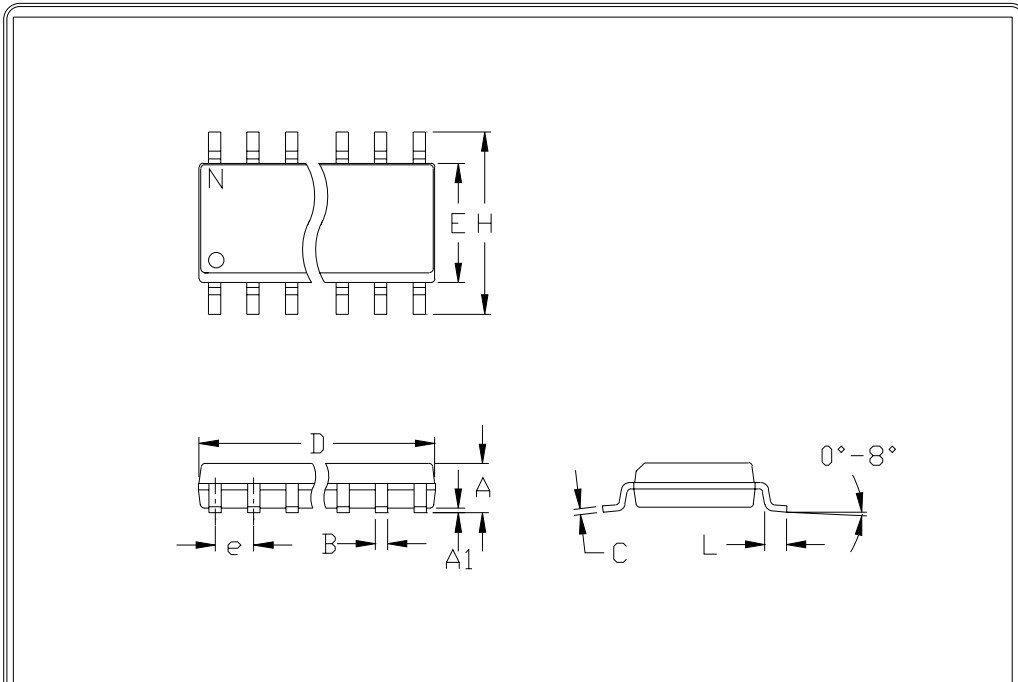

	INCHES		MILLIMETERS	
	MIN	MAX	MIN	MAX
A	0.053	0.069	1.35	1.75
A1	0.004	0.010	0.10	0.25
B	0.014	0.019	0.35	0.49
C	0.007	0.010	0.19	0.25
e	0.050		1.27	
E	0.150	0.157	3.80	4.00
H	0.228	0.244	5.80	6.20
h	0.010	0.020	0.25	0.50
L	0.016	0.050	0.40	1.27

	INCHES		MILLIMETERS		N	MS012
	MIN	MAX	MIN	MAX		
D	0.189	0.197	4.80	5.00	8	A
D	0.337	0.344	8.55	8.75	14	B
D	0.386	0.394	9.80	10.00	16	C

- NOTES:
1. D&E DO NOT INCLUDE MOLD FLASH
 2. MOLD FLASH OR PROTRUSIONS NOT TO EXCEED .15mm (.006")
 3. LEADS TO BE COPLANAR WITHIN .102mm (.004")
 4. CONTROLLING DIMENSION: MILLIMETER
 5. MEETS JEDEC MS012-XX AS SHOWN IN ABOVE TABLE
 6. N = NUMBER OF PINS

 <small>120 SAN GABRIEL DR. SUNNYVALE CA 94086 FAX (408) 737 7594</small> <small>PROPRIETARY INFORMATION</small>	PACKAGE FAMILY OUTLINE: SOIC .150"		21-0041	A
			DOCUMENT CONTROL NUMBER	REV

Maxim cannot assume responsibility for use of any circuitry other than circuitry entirely embodied in a Maxim product. No circuit patent licenses are implied. Maxim reserves the right to change the circuitry and specifications without notice at any time.

12 _____ **Maxim Integrated Products, 120 San Gabriel Drive, Sunnyvale, CA 94086 408-737-7600**

SITE
SEARCHPART NO.
SEARCH

WHAT'S NEW

PRODUCTS

SOLUTIONS

DESIGN

APPNOTES

SUPPORT

BUY

COMPANY

MEMBERS

MAX4575

Part Number Table

Notes:

1. See the [MAX4575 QuickView Data Sheet](#) for further information on this product family or download the [MAX4575 full data sheet](#) (PDF, 272KB).
2. Other options and links for purchasing parts are listed at: <http://www.maxim-ic.com/sales>.
3. [Didn't Find What You Need?](#) Ask our applications engineers. Expert assistance in finding parts, usually within one business day.
4. Part number suffixes: T or T&R = tape and reel; + = RoHS/lead-free; # = RoHS/lead-exempt. More: See [full data sheet](#) or [Part Naming Conventions](#).
5. * Some packages have variations, listed on the drawing. "PkgCode/Variation" tells which variation the product uses.

Part Number	Free Sample	Buy Direct	Package: TYPE PINS SIZE DRAWING CODE/VAR *	Temp	RoHS/Lead-Free? Materials Analysis
MAX4575ESA+	<input type="checkbox"/>	<input type="checkbox"/>	SOIC ;8 pin;.150" Dwg: 21-0041B (PDF) Use pkgcode/variation: S8+4*	-40C to +85C	RoHS/Lead-Free: Yes Materials Analysis
MAX4575ESA+T	<input type="checkbox"/>	<input type="checkbox"/>		-40C to +85C	RoHS/Lead-Free: Yes
MAX4575ESA	<input type="checkbox"/>	<input type="checkbox"/>	SOIC ;8 pin;.150" Dwg: 21-0041B (PDF) Use pkgcode/variation: S8-4*	-40C to +85C	RoHS/Lead-Free: No Materials Analysis
MAX4575ESA-T	<input type="checkbox"/>	<input type="checkbox"/>		-40C to +85C	RoHS/Lead-Free: No
MAX4575EUA	<input type="checkbox"/>	<input type="checkbox"/>	uMAX;8 pin;3 x 3mm Dwg: 21-0036J (PDF) Use pkgcode/variation: U8C-3*	-40C to +85C	RoHS/Lead-Free: No Materials Analysis
MAX4575EUA-T	<input type="checkbox"/>	<input type="checkbox"/>	uMAX;8 pin;3 x 3mm Dwg: 21-0036J (PDF) Use pkgcode/variation: U8C-3*	-40C to +85C	RoHS/Lead-Free: No Materials Analysis
MAX4575EUA+	<input type="checkbox"/>	<input type="checkbox"/>	uMAX;8 pin;3 x 3mm Dwg: 21-0036J (PDF) Use pkgcode/variation: U8C+3*	-40C to +85C	RoHS/Lead-Free: Yes Materials Analysis

MAX4575EUA+T

uMAX;8 pin;3 x 3mm
Dwg: [21-0036J](#) (PDF)
Use pkgcode/variation: U8C+3*

-40C to +85C

RoHS/Lead-Free: [Yes](#)
[Materials Analysis](#)

[Didn't Find What You Need?](#)

[CONTACT US: SEND US AN EMAIL](#)

Copyright 2007 by Maxim Integrated Products, Dallas Semiconductor • [Legal Notices](#) • [Privacy Policy](#)