

*MiniSafe 4800 Series Safety Light Curtains*  
*5-Pin Version*  
*Installation and Operating Manual*





# MS4800 Series Safety Light Curtain

## Contents

Section 1 -- Important Safety Warnings . . . . .	page 6
Section 2 -- Significant Features . . . . .	page 7
2.1 MS4800 Series Features . . . . .	page 7
2.2 System Components and Indicators . . . . .	page 7
Section 3 -- System Operation . . . . .	page 9
3.1 Operating States . . . . .	page 9
3.1.1 MACHINE RUN . . . . .	page 9
3.1.2 MACHINE STOP . . . . .	page 9
3.1.3 INTERLOCK . . . . .	page 9
3.1.4 ALARM . . . . .	page 9
3.2 Operating Modes . . . . .	page 9
3.2.1 Automatic Start . . . . .	page 10
3.2.2 Start/Restart Interlock . . . . .	page 10
3.3 MSF4800 Cascaded Series . . . . .	page 10
3.3.1 MSF4800 Requirements . . . . .	page 10
3.3.2 MSF4800 Segment Reduction Restart procedure . . . . .	page 11
Section 4 -- Detection Options . . . . .	page 12
4.1 Fixed Blanking . . . . .	page 12
4.1.1 Selecting Fixed Blanking with Selector Switches . . . . .	page 13
4.2 Floating Blanking . . . . .	page 16
4.2.1 Selecting Floating Blanking with Selector Switches . . . . .	page 16
4.3 Fixed Blanking with Floating Blanking . . . . .	page 17
4.3.1 The Effect of Fixed or Monitored Blanking or Floating Blanking on Minimum Object Resolution . . . . .	page 17
4.4 Optical Synchronization . . . . .	page 18
Section 5 -- Diagnostic and Test Features . . . . .	page 19
5.1 Individual Beam Indicators . . . . .	page 19
5.2 External Device Monitoring (EDM) - also known as MPCE Monitoring . . . . .	page 19
5.3 Range Selection . . . . .	page 19
Section 6 -- Using Selector Switches To Set Features . . . . .	page 20

6.1	<i>Manual Selector Switch version</i> .....	page 20
6.2	<i>Access to the Selector Switches</i> .....	page 20
6.2.1	<i>Transmitter Selector Switch Settings</i> .....	page 20
6.2.2	<i>Receiver Selector Switch Settings</i> .....	page 21
6.3	<i>Operating Mode Selection</i> .....	page 21
6.4	<i>Selecting and Programming Fixed Blanking</i> .....	page 21
6.5	<i>Selecting Floating Blanking</i> .....	page 21
6.6	<i>Selecting Scan Codes</i> .....	page 21
<i>Section 7 -- Outputs</i> .....		page 22
7.1	<i>Safety Outputs</i> .....	page 22
<i>Section 8 -- Safe Mounting Distance</i> .....		page 23
8.1	<i>US Safety Distance Formulas</i> .....	page 23
8.2	<i>European Safety Distance Formulas</i> .....	page 24
8.2.1	<i>Safety Distance Formula for Systems with a Minimum Object Resolution of 40 mm or Less</i> .....	page 24
8.2.2	<i>Safety Distance Formula for Systems with a Minimum Object Resolution Greater Than 40 mm</i> .....	page 24
8.2.3	<i>Factors Affecting the Safety Distance Formula</i> .....	page 25
<i>Section 9 -- Installation</i> .....		page 26
9.1	<i>Reflective Surface Interference</i> .....	page 26
9.2	<i>Cross Talk Mitigation</i> .....	page 27
9.3	<i>General Mounting Considerations</i> .....	page 28
9.3.1	<i>Additional Guarding</i> .....	page 28
9.3.2	<i>Added Mounting Rigidity</i> .....	page 28
9.3.3	<i>Installation of Multiple Systems</i> .....	page 29
9.3.4	<i>Detection Zone</i> .....	page 29
9.3.5	<i>Alignment</i> .....	page 29
9.3.6	<i>Input Power Requirements</i> .....	page 29
9.3.7	<i>Requirements for Perimeter Guarding</i> .....	page 30
9.3.8	<i>Marking Minimum Object Resolution</i> .....	page 30
9.3.9	<i>Presence Sensing Device Initiation</i> .....	page 30
<i>Section 10 -- Connecting To The Machine Control Circuit</i> .....		page 31

10.1	<i>Connecting to a Safety Monitoring Device</i>	page 32
10.2	<i>Connecting Via an RM-1 Module</i>	page 33
10.3	<i>Connecting Via an RM-2AC Module</i>	page 34
10.4	<i>Connecting Via Two Force-Guided Relays</i>	page 35
10.5	<i>Connecting Via An RM-2AC-IP</i>	page 36
<i>Section 11 -- Checkout and Test Procedures</i>		page 37
11.1	<i>Checkout Procedure</i>	page 37
11.2	<i>Test Procedure</i>	page 37
11.3	<i>Using the Test Object</i>	page 37
<i>Section 12 -- Cleaning</i>		page 38
<i>Section 13 -- Specifications and Additional Information</i>		page 39
13.1	<i>System Specifications</i>	page 39
13.2	<i>Cable Lengths (Customer supplied cables)</i>	page 40
13.3	<i>MiniSafe MS4800 Dimensional Drawings</i>	page 41
13.4	<i>MiniSafe Cascaded MSF4800 Dimension drawings</i>	page 45
13.5	<i>Warranty</i>	page 49
13.6	<i>Patents</i>	page 49
13.7	<i>Trademarks</i>	page 49
13.8	<i>Repairs</i>	page 49
13.9	<i>Documentation Criteria</i>	page 50
13.10	<i>Compliance with RoHS</i>	page 50
<i>Section 14 -- Glossary</i>		page 51
<i>Section 15 -- Diagnostics &amp; Troubleshooting</i>		page 52
15.1	<i>Diagnostics</i>	page 52
15.2	<i>Receiver Diagnostic Information</i>	page 54
15.3	<i>Receiver Endcap Indicator Lights</i>	page 54
15.3.1	<i>Receiver Troubleshooting</i>	page 54
15.4	<i>Troubleshooting the Transmitter</i>	page 55
<i>Appendix A —Checkout Procedure</i>		page 56
<i>Appendix B —Test Procedure</i>		page 57

## Figures

Figure 2-1 <i>MS4800 Access to Features</i> . . . . .	page 7
Figure 2-2 <i>System Components</i> . . . . .	page 8
Figure 3-1 <i>Cascaded MSF4800</i> . . . . .	page 11
Figure 4-1 <i>Adding Hard Guarding to Light Curtain when Using Fixed Blanking</i> . . . . .	page 12
Figure 4-2 <i>Selecting Fixed Blanking Procedure 1</i> . . . . .	page 13
Figure 4-3 <i>Selecting Fixed Blanking Procedure 2</i> . . . . .	page 14
Figure 4-4 <i>Selecting Fixed Blanking Procedure 3</i> . . . . .	page 14
Figure 4-5 <i>Selecting Fixed Blanking Procedure 4</i> . . . . .	page 14
Figure 4-6 <i>Selecting Fixed Blanking Procedure 5</i> . . . . .	page 15
Figure 4-7 <i>Selecting Fixed Blanking Procedure 6</i> . . . . .	page 15
Figure 6-1 <i>MS4800S Selector switches</i> . . . . .	page 20
Figure 6-2 <i>Transmitter Selector Switches</i> . . . . .	page 20
Figure 6-3 <i>Receiver Selector Switch Settings</i> . . . . .	page 21
Figure 8-1 <i>Safe Mounting Distance</i> . . . . .	page 23
Figure 9-1 <i>Worst Case Alignment Example</i> . . . . .	page 26
Figure 9-2 <i>Unsafe Mounting Example (1)</i> . . . . .	page 26
Figure 9-3 <i>Unsafe Mounting Example (2)</i> . . . . .	page 26
Figure 9-4 <i>Correct Mounting Example with Proper Alignment</i> . . . . .	page 27
Figure 9-5 <i>Minimum Distance from a Reflective Surface as a Function of Range</i> . . . . .	page 27
Figure 9-6 <i>Correct Light Curtain Installation Example</i> . . . . .	page 28
Figure 9-7 <i>Adding Mounting Bracket</i> . . . . .	page 28
Figure 9-8 <i>Multiple Light Curtain Installation Configurations</i> . . . . .	page 29
Figure 9-9 <i>Multiple Light Curtain Installation Configurations using Scan Codes</i> . . . . .	page 29
Figure 10-1 <i>Connecting to a Safety Monitoring Device</i> . . . . .	page 32
Figure 10-2 <i>Connecting via an RM-1 Module</i> . . . . .	page 33
Figure 10-3 <i>Connecting via an RM-2AC Module</i> . . . . .	page 34
Figure 10-4 <i>Connecting Via Two Force-guided Relays</i> . . . . .	page 35
Figure 10-5 <i>Connecting Via An RM-2AC-IP Module</i> . . . . .	page 36
Figure 11-1 <i>Test Object Pattern</i> . . . . .	page 37
Figure 13-1 <i>MS4800 Dimensional Drawing</i> . . . . .	page 41
Figure 13-2 <i>MSF4800 Dimension Drawings</i> . . . . .	page 45
Figure 15-1 <i>Example of IBI LED's used to Show Fault Code</i> . . . . .	page 54

## Tables

Table 2-1 <i>System Components Identification</i> . . . . .	page 8
Table 4-1 <i>Tolerance Effect of Fixed Blanked area on Resolution</i> . . . . .	page 13
Table 4-2 <i>Diagram of Operation</i> . . . . .	page 16
Table 4-3 <i>System Response to Floating Blanking</i> . . . . .	page 17
Table 4-4 <i>Floating Blanking Effects on Resolution</i> . . . . .	page 17
Table 4-5 <i>Sample S and <math>D_{pf}</math> Factors for MS4800-14 System</i> . . . . .	page 18
Table 4-6 <i>Sample S and <math>D_{pf}</math> Factors for MS4800-20 System</i> . . . . .	page 18
Table 4-7 <i>Sample S and <math>D_{pf}</math> Factors for MS4800-30 System</i> . . . . .	page 18
Table 4-8 <i>Sample S and <math>D_{pf}</math> Factors for MS4800-40 System</i> . . . . .	page 18
Table 4-9 <i>Synchronization Requirements</i> . . . . .	page 19
Table 6-1 <i>Transmitter Selector Switch Settings</i> . . . . .	page 20
Table 6-2 <i>Receiver Selector Switch Settings</i> . . . . .	page 21
Table 13-1 <i>System Specifications</i> . . . . .	page 39
Table 13-2 <i>Response Time of MS/MSF4800 System</i> . . . . .	page 40
Table 13-3 <i>MS4800 Input &amp; Output Signal Cable Lengths</i> . . . . .	page 40
Table 13-4 <i>MS4800-14/20 Transmitter and Receiver Dimensions</i> . . . . .	page 42
Table 13-5 <i>MS4800-30 Transmitter and Receiver Dimensions</i> . . . . .	page 43
Table 13-6 <i>MS4800-40 Transmitter and Receiver Dimensions</i> . . . . .	page 44
Table 13-7 <i>MSF4800-14/20 Transmitter and Receiver Dimensions</i> . . . . .	page 46
Table 13-8 <i>MSF4800-30 Transmitter and Receiver Dimensions</i> . . . . .	page 47
Table 13-9 <i>MSF4800-40 Transmitter and Receiver Dimensions</i> . . . . .	page 48
Table 15-1 <i>Diagnostic Codes</i> . . . . .	page 52

# 1 IMPORTANT SAFETY WARNINGS

**▲ WARNING! Read and understand this section prior to installing an MS4800 system.**

An MS4800 system is a general purpose presence sensing device designed to guard personnel working around moving machinery.

Whether a specific machine application and MS4800 system installation complies with safety regulations depends on the proper application, installation, maintenance and operation of the MS4800 system. These items are the responsibility of the purchaser, installer and employer.

The employer is responsible for the selection and training of personnel to properly install, operate, and maintain the machine and its safeguarding systems. An MS4800 system should only be installed, verified and maintained by a *qualified* person. A qualified person is defined as “*an individual who understands, is trained on, and demonstrates competence with the construction, operation or maintenance of the machinery and the hazards involved.*” (ANSI/PMMA B155.1-2006)

To use an MS4800 system the following requirements must be met:

- The guarded machine must be able to stop anywhere in its cycle. Do not use a safety light curtain on a press with a full-revolution clutch.
- The guarded machine must not present a hazard from flying parts.
- The guarded machine must have a consistent stopping time and adequate control mechanisms.
- Severe smoke, particulate matter and corrosives may degrade the efficiency of a safety light curtain. Do not use an MS4800 system in this type of environment.
- All applicable governmental and local rules, codes, and regulations must be satisfied. This is the employer’s responsibility.
- All safety-related machine control elements must be designed so that an alarm in the control logic or failure of the control circuit does not lead to a failure to danger.
- Additional guarding may be required for access to dangerous areas not covered by the MS4800 system.
- Perform the Omron STI test procedure at installation and after maintenance, adjustment, repair or modification to the machine controls, tooling, dies or machine, or the MS4800 system.
- Perform only the test and repair procedures outlined in this manual.
- Follow all procedures in this manual for proper operation of the MS4800 system.

The enforcement of these requirements is beyond the control of Omron STI. The employer has the sole responsibility to follow the preceding requirements and any other procedures, conditions and requirements specific to his machinery.

## 2 SIGNIFICANT FEATURES

The MS4800S is configured through selector switches located under an access cover.

### 2.1 MS4800 SERIES FEATURES

- Flex Bus, Multi-Segmented Head Configurations
- Scan Code for Cross-Talk Mitigation
- Adjustable Mounting Brackets and T-slots
- Non-shielded Main Cables
- 2-box Design
- Two PNP Safety Outputs
- Operating Mode (Automatic Start)
- Floating Blanking
- Fixed Blanking
- Range Selection

### 2.2 SYSTEM COMPONENTS AND INDICATORS

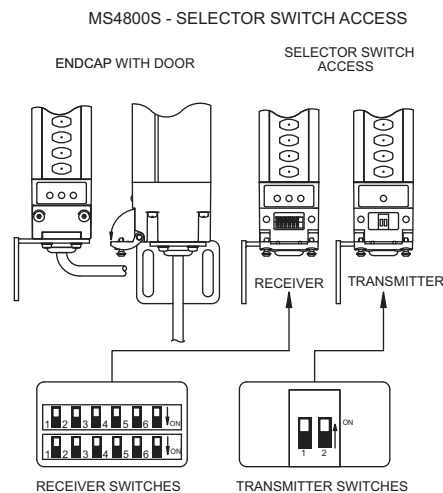

Figure 2-1 MS4800 Access to Features

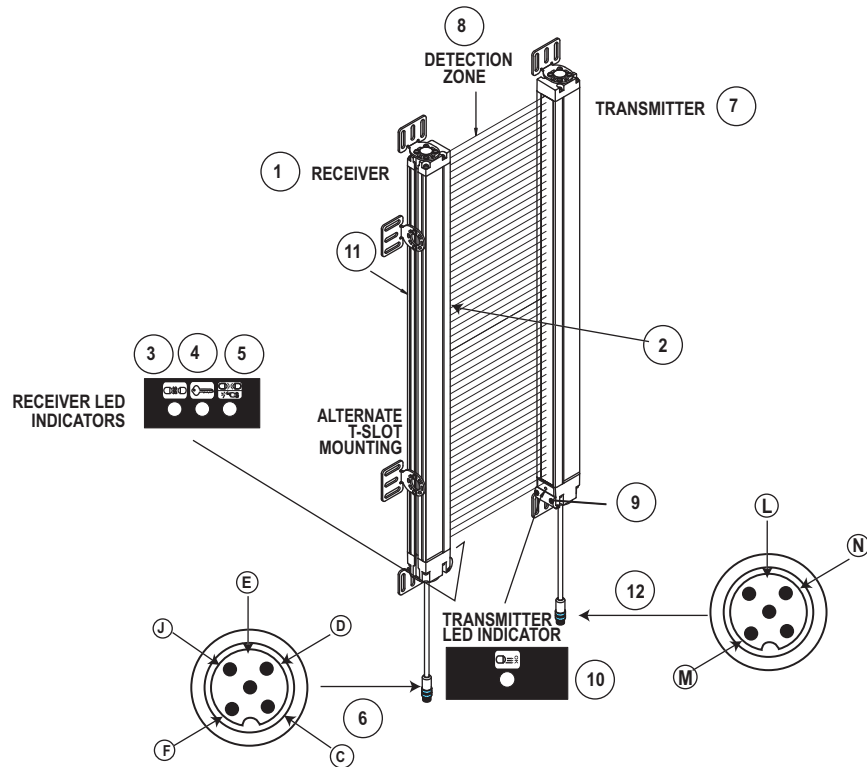

Figure 2-2 System Components

Table 2-1 System Components Identification

Chart #		Chart #	
1	<b>RECEIVER</b>	7	<b>TRANSMITTER</b>
2	Individual Beam Indicators (one for each beam) - Red	8	Detection Zone
3	Blanking Active - Amber	9	Flip door. Access to configuration switches (on both receiver & transmitter)
4	INTERLOCK or ALARM Indicator - Yellow	10	Status Indicator - Yellow
5	MACHINE RUN/STOP Indicator - Green/Red	11	Side Mounting T-Slot
6	<b>RECEIVER CONNECTIONS M-12 (Male)</b>	12	<b>TRANSMITTER CONNECTIONS M-12 (Male)</b>
	F +24 VDC - Blue Wire		M +24 VDC - Blue Wire
	D 0 VDC - White Wire		N 0 VDC - White Wire
	C OSSD 1 - Black Wire		L Earth - Green Wire
	J OSSD 2 - Brown Wire		
	E Earth - Green Wire		

## 3 SYSTEM OPERATION

The MS4800 system is a microprocessor-controlled, infrared, transmitted-beam safety light curtain. The system consists of a receiver assembly and a transmitter assembly. The receiver and transmitter assemblies are not physically interconnected.

An MS4800 system is used where personnel protection is required. Typical applications include mechanical power presses, robotic work cells, filter presses, injection molders, food processing equipment and automated assembly equipment.

### 3.1 OPERATING STATES

The operating condition of an MS4800 system is described in terms of states. The following operating states exist for an MS4800 system.

#### 3.1.1 MACHINE RUN

The two receiver safety outputs are in the ON state, the green MACHINE RUN indicator is lit, and the auxiliary output is in a state consistent with its configuration. The protected machine is allowed to operate. Pressing and releasing the start button has no effect.

#### 3.1.2 MACHINE STOP

The two receiver safety outputs are in the OFF state, the red MACHINE STOP indicator is lit, and the auxiliary output is in a state consistent with its configuration. The protected machine is not allowed to operate.

#### 3.1.3 INTERLOCK

The two receiver safety outputs are in the OFF state, the red MACHINE STOP indicator and yellow INTERLOCK indicator are lit. The auxiliary output is in a state consistent with its configuration. The INTERLOCK state does not allow the protected machine to operate until the detection zone is clear of obstructions and the start button is pressed and released.

#### 3.1.4 ALARM

The two receiver safety outputs are in the OFF state, the red MACHINE STOP indicator is lit, the yellow INTERLOCK indicator is flashing, and the auxiliary output is in the OFF state. The alarm state does not allow the protected machine to operate. The primary difference between alarm and INTERLOCK is that the MS4800 system will remain in the alarm state until the alarm is corrected, regardless of power cycling.

### 3.2 OPERATING MODES

System operating modes determine the start-up and operating behavior of an MS4800 system. Operating mode definitions rely on the operating states presented above. Operating mode selection is configured via switches on the MS4800S in the receiver and transmitter.

**NOTE!** *If internal alarms are detected by the system during power-up or operation, it will enter the ALARM state with its safety outputs in the OFF state.*

### 3.2.1 AUTOMATIC START

The MS4800 will power-up with its safety and auxiliary outputs OFF, and, if the detection zone is not obstructed, enters the MACHINE RUN state. In this state, when an object is sensed entering the detection zone, the MS4800 system will change from MACHINE RUN to MACHINE STOP and remain in this state until the obstruction is removed. Once the detection zone is clear, the MS4800 system will automatically change from MACHINE STOP to MACHINE RUN.

### 3.2.2 START/RESTART INTERLOCK

The MS4800 will power up with its safety outputs off and enter the INTERLOCK state if the detection zone is clear (or the Fixed or Monitoring Blanking pattern is satisfied, if enabled) and no alarms are detected. To initially enter the MACHINE RUN state the operator must press and release the Start button. Once in the MACHINE RUN state, when an object is sensed entering the detection zone, the system will change to the MACHINE STOP state. When the detection zone is cleared, the system will not automatically change to MACHINE RUN but enter the INTERLOCK state instead. The operator must always press and release the Start button to enter MACHINE RUN. If the detection zone is not clear the Start button will have no effect.

**NOTE!** *The definitions above mention a start button. The 5-pin version does not have a start button input and should only be used in Automatic Start mode.*

## 3.3 MSF4800 CASCADED SERIES

The MiniSafe 4800 series safety light curtain is available in a “cascaded” version, referred to as the MSF4800 series. The MSF4800 series allows multiple transmitters/receivers to be “daisy-chained” in series. This type of arrangement permits the MSF4800 to guard multiple areas of a machine.

### 3.3.1 MSF4800 REQUIREMENTS

The MSF4800 is offered in protective heights ranging from 240mm to 1800mm for 14/20mm resolutions, 240mm to 2120mm for 30mm, and resolutions and from 360mm to 2040mm for 40mm resolutions.

- An MSF4800 system has a maximum size limitation based on the number of beams. A single master segment cannot exceed 180 beams and the total of the combined segments cannot exceed 256 beams.
- A single slave segment cannot exceed 128 beams.
- An MSF4800 system may have up to four daisy-chained segments, including the first segment. As long as the total number of beams does not exceed 256.
- The interconnect cable length limitation between any two segments is 10 meters.
- It is possible to mix segments with different resolutions within an MSF4800 system.

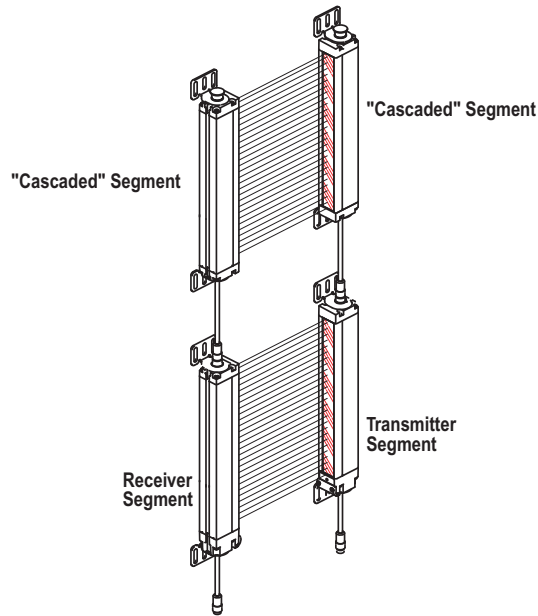

Figure 3-1 Cascaded MSF4800

### 3.3.2 MSF4800 SEGMENT REDUCTION RESTART PROCEDURE

If you reduce the number of cascaded segments while power is on, you will cause a flex bus fault. The MSF4800 will enter a fault condition, indicated by error code "95" on the IBIs. After power cycling the system to clear the flex fault, fault code "100" will be displayed. If the number of segments is reduced while power is off, the light curtain will power on with fault code "100". (NOTE: this will appear as one IBI led on). This fault code indicates that there was a reduction in the number of cascaded segments.

To clear this fault and restore operation on the reduced size MSF4800 the following procedure must be followed.

1. Apply power, if power is applied the power must be cycled.
2. The three indicator LEDs (red, yellow, amber) will flash for 60 seconds.
3. While the LEDs are flashing, the EDM switches must be cycled in the following sequence:
  - a. Flip SW A EDM switch from Off to On position.
  - b. Flip SW B EDM switch from Off to On position.
  - c. Flip SW A EDM switch from On to Off position.
  - d. Flip SW B EDM switch from On to Off position.
4. Toggle the SW A Program switch On-off-On, or (off-on-off)
5. The 4800 will then reset itself.

The transmitter will not fault if the number of segments is reduced. However, to operate normally the transmitter must always match the receiver in the number of segments and beams.

## 4 DETECTION OPTIONS

**▲ Warning!** Use of Fixed or Floating Blanking will make an MS4800 system less sensitive to objects in the detection zone. Improper use of these features can result in severe injury to personnel. Fixed Blanking may require a hard barrier guard. Fixed Blanking and Floating Blanking may require an increase in the safety distance. Read the following section carefully.

### 4.1 FIXED BLANKING

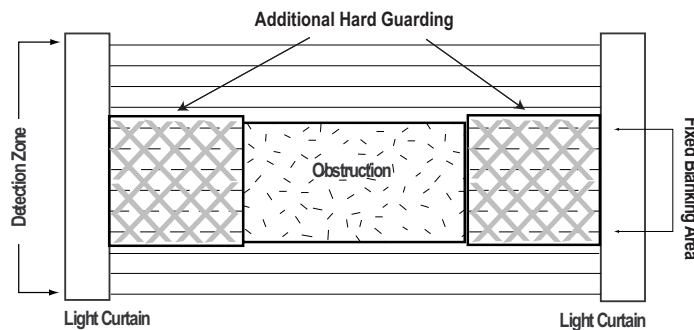

Figure 4-1 Adding Hard Guarding to Light Curtain when Using Fixed Blanking

Fixed Blanking allows a system to blank optical beams and record the exact pattern. A system can record and store a single pattern. The protected zone's object detection is then based on the stored pattern. All obstructed optical beams recorded during the selection must remain blocked and all clear beams recorded during the selection must remain clear for the system to enter or remain in the MACHINE RUN state.

A Fixed Blanking pattern may consist of more than one Fixed Blanked area. Individual Fixed Blanked areas must be separated by at least one beam that is always clear. A Fixed Blanking area may not crossover between "flexible" segment boundaries.

"Each Fixed Blanked area has a size and positional tolerance of +/- 1 beam to allow for small positional variations where only the beams on the edges of the blanked area are allowed to change. Because of this position tolerance, a reduction of the optical resolution occurs on the border areas of the Fixed Blanking patterns. See Table 4-1 *Tolerance Effect of Fixed Blanked area on Resolution*. The effect of this tolerance also allows the number of blocked beams to change by +/- 1 beam. For example, a Fixed Blanked area of 8 blanked beams is allowed to increase to 9 beams or decrease to 7 beams and the light curtain will remain in MACHINE RUN." If there is a one or two beam gap between objects the objects cannot use their beam tolerances to close the gap and combine into one single fixed blanking area. In addition if there is a one beam gap between objects, the object closest to the entry encap cannot use the clear beam towards its tolerance even if the adjacent object moved in the same direction by one beam..

**Table 4-1 Tolerance Effect of Fixed Blanked area on Resolution**

Standard Resolution	Effective Resolution at Ends of Fixed Blanked Area
14mm	34mm
20mm	40mm
30mm	60mm
40mm	80mm

**Note:** The tolerance does not reduce the resolution of the entire light curtain, only the ends of Fixed Blanked Areas. The user must consider the increased resolution of the two beams at the ends of each Fixed Blanked Area.

The minimum number of beams in a Fixed Blanking area is one. If only one beam is blanked, there is no positional tolerance. The beam programmed to be blocked must remain blocked. The number of blocked beams has a size tolerance of +1/-0 meaning the number of blocked beams can increase to two but the area cannot be completely eliminated.

The Fixed Blanking pattern must not prevent the light curtain from synchronizing. This means that the size of the blanked object can not exceed certain limits as long as synchronization is maintained, see *Table 4-9*.

Fixed Blanking is allowed during all modes of operation (Automatic Start, Start, Start Interlock, and Start/Restart Interlock.)

To use Fixed Blanking, the operator enables the option using the selector switches. A new Fixed Blanking pattern is recorded when the MS4800 receiver is in MACHINe STOP, the blanking function is active and the Program function is activated. If the Fixed Blanking feature is disabled, the stored protected zone patterns are cleared.

**4.1.1 SELECTING FIXED BLANKING WITH SELECTOR SWITCHES**

The obstruction is placed within the detection zone and the receiver goes to MACHINe STOP state. An authorized user then sets the selector switches in the receiver endcap to select Fixed Blanking Enable. The MS4800 enters a fault state and power is cycled or the Start switch is activated to clear the fault. When the receiver powers up it will be in Fixed Blanking mode with the red and amber LEDs lit. See *Figure 4-2 Selecting Fixed Blanking Procedure 1*.

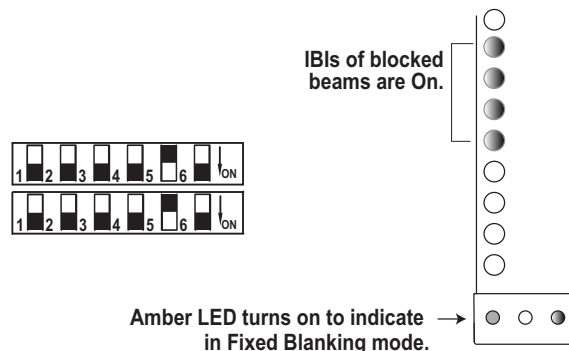

*Figure 4-2 Selecting Fixed Blanking Procedure 1*

The authorized user then enables the Program switch by setting both Fixed Blanking switches to the off position and then both to the on position. When the first Fixed Blanking switch is flipped, the red LED begins flashing at a rate of 3 Hz. When the final Fixed Blanking switch is flipped, both the red and amber LEDs and the IBIs of the blocked beams start flashing to indicate the Program switch is enabled.

The authorized user has 10 minutes to complete the programming of a pattern. See Figure 4-3 *Selecting Fixed Blanking Procedure 2*.

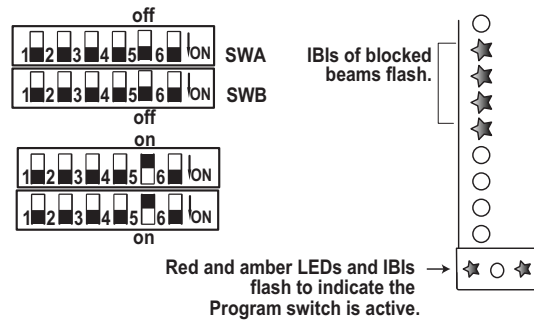

Figure 4-3 *Selecting Fixed Blanking Procedure 2*

To program a pattern, the authorized user must flip (off/on or on/off) the Program switch once. Once a pattern is programmed the yellow LED (INTERLOCK) turns on. During the 10 minute period, the user may program as many times as needed, allowing for adjustment in the placement of the obstruction. See Figure 4-4 *Selecting Fixed Blanking Procedure 3*.

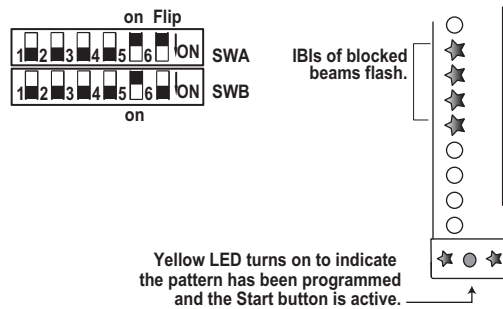

Figure 4-4 *Selecting Fixed Blanking Procedure 3*

The user must then press and release the START button or perform a power cycle. The MS4800 receiver then resets. If no faults are detected and the state of the optical beams matches the recorded Fixed Blanking pattern, the receiver will enter the INTERLOCK or MACHINE RUN condition depending upon the selected Start Mode. The amber receiver Blanking Active LED will be on. See Figure 4-5 *Selecting Fixed Blanking Procedure 4*.

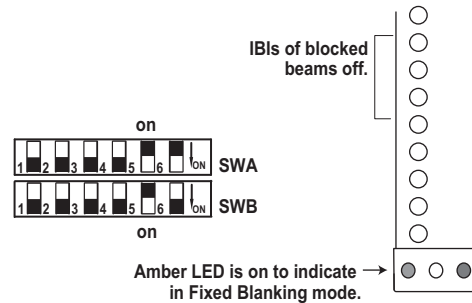

Figure 4-5 *Selecting Fixed Blanking Procedure 4*

If the 10 minute period expires, the amber LED and IBIs quit flashing and the yellow LED (INTERLOCK) goes on. The user can start another programming sequence by setting both Fixed

Blanking switches off and then on. The user may start normal operation by a press and release of the Start button or by performing a power cycle. See Figure 4-6 *Selecting Fixed Blanking Procedure 5*.

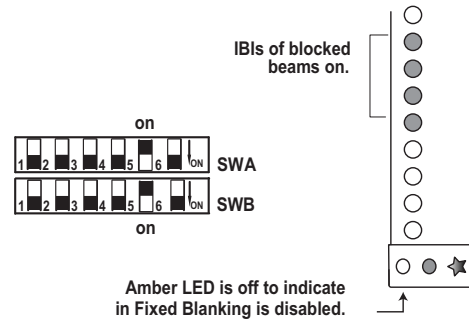

Figure 4-6 *Selecting Fixed Blanking Procedure 5*

To exit Fixed Blanking the user sets both selector switches to the off position, then either presses and releases the Start button or performs a power cycle. The receiver will power up with the amber LED off.

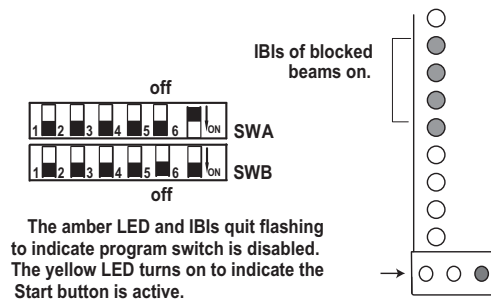

Figure 4-7 *Selecting Fixed Blanking Procedure 6*

Table 4-2 Diagram of Operation

No Fixed Blanking	Fixed Blanking Enabled	Fixed Blanking Enabled	Fixed Blanking Enabled	Fixed Blanking Enabled	Fixed Blanking Enabled
○	○	○	○	⊗	○
○	⊗	○	○	⊗	⊗
○	⊗	○	●	●	⊗
●	⊗	⊗	⊗	⊗	⊗
○	○	○	⊗	○	○
MACHINE STOP	MACHINE RUN	MACHINE RUN	MACHINE RUN	MACHINE STOP	MACHINE STOP

○ Clear Optical Channel      ● Blocked Optical Channel      ⊗ Optical Channel Selected by Fixed Blanking

## 4.2 FLOATING BLANKING

**▲ Warning!** *Use of Fixed Blanking and Floating Blanking will make the MS4800 system less sensitive to objects in the detection zone. Improper use of these features can result in severe injury to personnel. Fixed Blanking may require a hard barrier guard. Fixed Blanking and Floating Blanking may require an increase in the safety distance. Read the following section carefully.*

Up to two channels can be obstructed at any location in the detection zone (one channel on MS4800S) as long as synchronization is maintained, see *Table 4-9*.

This means that an object can freely float from one end of the protective field to the other without the MS4800 system entering the MACHINE STOP state. The obstructed channels are not fixed at a single location but “float” through the detection zone.

See *Table 4-3* for a diagram of MS4800 system response during operation with Floating Blanking active.

### 4.2.1 SELECTING FLOATING BLANKING WITH SELECTOR SWITCHES

Using the selector switches an authorized user can activate the Floating Blanking function. This allows the system to operate with one obstructed optical beam anywhere within the protected zone. This obstruction is permitted anywhere within the protected zone and is permitted to move over time. After setting the appropriate selector switches, the receiver enters the Power-On Self Test state and if no faults are detected the receiver shall enter the INTERLOCK or MACHINE RUN condition depending upon the selected operating mode.

**NOTE:** *Two-beam floating is not available on the MS4800S.*

**Table 4-3 System Response to Floating Blanking**

	Floating Blanking Inactive	1 Channel Floating Blanking Active	1 Channel Floating Blanking Active	1 Channel Floating Blanking Active	1 Channel Floating Blanking Active	2 Channel Floating Blanking Active	2 Channel Floating Blanking Active	2 Channel Floating Blanking Active	2 Channel Floating Blanking Active	2 Channel Floating Blanking Active	2 Channel Floating Blanking Active	2 Channel Floating Blanking Active
Channel 1	○	○	○	○	○	○	○	○	○	○	○	⊗
Channel 2	○	○	○	⊗	⊗	○	○	⊗	⊗	⊗	⊗	○
Channel 3	⊗	○	⊗	⊗	○	○	⊗	⊗	○	⊗	○	⊗
Channel 4	○	○	○	○	⊗	○	○	○	⊗	⊗	⊗	○
Channel 5	○	○	○	○	○	○	○	○	○	○	⊗	⊗
System Response	1 Exception MACHINE STOP	0 Exceptions Machine Run	1 Exception Machine Run	2 Exceptions MACHINE STOP	2 Exceptions MACHINE STOP	0 Exceptions Machine Run	1 Exception Machine Run	2 Exceptions Machine Run	2 Exceptions Machine Run	3 Exceptions MACHINE STOP	3 Exceptions MACHINE STOP	3 Exceptions MACHINE STOP

○ Clear Optical Channel      ⊗ Optical Channel is Blocked

**Table 4-4 Floating Blanking Effects on Resolution**

Floating Blanking Effects on Minimum Object Resolution		
Standard Minimum Objection Resolution (No Floating Blanking)	Minimum Object Resolution with 1 Beam Floating	Minimum Object Resolution with 2 Beam Floating
14mm	24mm	34mm
20mm	30mm	40mm
30mm	50mm	70mm
40mm	70mm	100mm

**4.3 FIXED BLANKING WITH FLOATING BLANKING**

**▲ Warning! Use of Fixed Blanking, and Floating Blanking will make the MS4800 system less sensitive to objects in the detection zone. Improper use of these features can result in severe injury to personnel. Fixed Blanking may require a hard barrier guard. Fixed Blanking and Floating Blanking may require an increase in the safety distance. Read the following section carefully.**

When both Fixed Blanking and Floating Blanking are selected, the floating channels are allowed to occur anywhere within the detection zone except the area selected by Fixed Blanking.

**4.3.1 THE EFFECT OF FIXED OR MONITORED BLANKING OR FLOATING BLANKING ON MINIMUM OBJECT RESOLUTION**

When Fixed Blanking and/or Floating Blanking are active, the safe mounting distance is affected. Fixed and Floating Blanking desensitize the light curtain and increase the size of the minimum detectable object. The increase is equal to the beam spacing distance for each beam that is disabled.

- A MiniSafe MS4800-20 system with one beam disabled has a minimum object resolution of: 20 mm + 10 mm = 30 mm (1.18 inches).
- A MiniSafe MS4800-20 system with two beams disabled has a minimum object resolution of:

20 mm + 10 mm + 10 mm = 40 mm (1.57 inches).

If the size of the object detected by the system increases, the minimum safe distance must also be increased. Use the minimum object sensitivity given in *Tables 5-4 through 5-7* to determine the new figure to use when computing the safety distance.

**Note:** *In some cases the use of mechanical hard guards may be needed to insure that the blanked areas are adequately guarded.*

**Table 4-5 Sample S and D<sub>pf</sub> Factors for MS4800-14 System**

Total Number of Beams Disabled by Fixed and/or Floating Blanking	Minimum Object Resolution S	Depth Penetration Factor, D <sub>pf</sub> for use with ANSI Formula (D <sub>pf</sub> = 3.4 (S-.276) inches)
None	14 mm (0.55 inches)	0.93 inches (24 mm)
1 Beam	24 mm (0.94 inches)	2.26 inches (57 mm)
2 Beams	34 mm (1.34 inches)	3.62 inches (92 mm)
3 Beams	44 mm (1.73 inches)	4.94 inches (125 mm)
4 Beams	54 mm (2.13 inches)	6.3 inches (160 mm)
5 Beams	64 mm (2.52 inches)	7.6 inches (193 mm)
	>64 mm (2.52 inches)	36 inches (900 mm)

**Table 4-6 Sample S and D<sub>pf</sub> Factors for MS4800-20 System**

Total Number of Beams Disabled by Fixed and/or Floating Blanking	Minimum Object Resolution S	Depth Penetration Factor, D <sub>pf</sub> for use with ANSI Formula (D <sub>pf</sub> = 3.4 (S-.276) inches)
None	20 mm (0.79 inches)	1.75 inches (43 mm)
1 Beam	30 mm (1.18 inches)	3.1 inches (78 mm)
2 Beams	40 mm (1.57 inches)	4.4 inches (111 mm)
3 Beams	50 mm (1.97 inches)	5.76 inches (146 mm)
4 Beams	60 mm (2.36 inches)	7.1 inches (180 mm)
	>64 mm (2.52 inches)	36 inches (900 mm)

**Table 4-7 Sample S and D<sub>pf</sub> Factors for MS4800-30 System**

Total Number of Beams Disabled by Fixed and/or Floating Blanking	Minimum Object Resolution S	Depth Penetration Factor, D <sub>pf</sub> for use with ANSI Formula (D <sub>pf</sub> = 3.4 (S-.276) inches)
None	30 mm (1.18 inches)	3.1 inches (78 mm)
1 Beam	50 mm (1.97 inches)	5.76 inches (146 mm)
	>64 mm (2.52 inches)	36 inches (900 mm)

**Table 4-8 Sample S and D<sub>pf</sub> Factors for MS4800-40 System**

Total Number of Beams Disabled by Fixed and/or Floating Blanking	Minimum Object Resolution S	Depth Penetration Factor, D <sub>pf</sub> for use with ANSI Formula (D <sub>pf</sub> = 3.4 (S-.276) inches)
None	40 mm (1.57 inches)	4.4 inches (112 mm)
	>64 mm (2.52 inches)	36 inches (900 mm)

#### 4.4 OPTICAL SYNCHRONIZATION

The synchronization between the MS4800 system transmitter and receiver is optical so the system does not use one specific beam. To establish synchronization the system needs to have a certain number of consecutive clear beams (Table 4-9 *Synchronization Requirements*) within the first master segment. If they are not satisfied, the system will enter a Machine Stop state and every other individual beam indicator will light. When the beams are clear, the system will re-synchronize itself and enter a state consistent with its operating mode. Once the synchronization is established, it can be maintained as long as the required number of consecutive clear beams can be satisfied anywhere in the system (including flex systems).

Because of this restrictions, when programming a fixed or monitored blanking object(s), the size of the fixed or monitored blanking object(s) must comply with the number of consecutive clear beams stated in *Table 4-9* within the first segment.

In addition to that, there must be at least one (2) clear beams on each flex segment.

**Table 4-9 Synchronization Requirements**

Light Curtain Beam Count	Synchronization Beam Requirement
12- 16 beams	6 consecutive clear beams
17 - 32 beams	7 consecutive clear beams
33 - 64 beams	8 consecutive clear beams
65 - 128 beams	9 consecutive clear beams
129 - 256 beams	10 consecutive clear beams

## 5 DIAGNOSTIC AND TEST FEATURES

# 5

### 5.1 INDIVIDUAL BEAM INDICATORS

All MS4800 systems have a visible, red, Individual Beam Indicator (IBI) adjacent to each infrared beam. These IBIs are located on the receiver. The IBI will light when the infrared beam fails to meet the conditions necessary for the system to remain in the MACHINE RUN state. When less than 10 consecutive beams are clear, every other IBI will light indicating that the MS4800 is not synchronized. IBIs are not a safety critical component. An IBI failure will not cause an alarm condition and the system will continue to operate.

### 5.2 EXTERNAL DEVICE MONITORING (EDM) - ALSO KNOWN AS MPCE MONITORING

EDM is not available on the 5-pin version of the MS4800. If external device monitoring is required, OMRON STI recommends the use of a safety monitoring relay in conjunction with the MS4800 light curtain.

### 5.3 RANGE SELECTION

The MS4800 offers operating range selection: short range is 8m and long range is 20m. This function is useful when there are many light curtains operating within a small space and the possibility of cross-talk is likely.

# 6 USING SELECTOR SWITCHES TO SET FEATURES

# 6

## 6.1 MANUAL SELECTOR SWITCH VERSION

The operating parameters of the MS4800S Series light curtains are configured via selector switches. See below.

## 6.2 ACCESS TO THE SELECTOR SWITCHES

The switches are located behind a flip door on both the transmitter and receiver. The flip up doors are opened by loosening two retaining screws. (see illustration below)

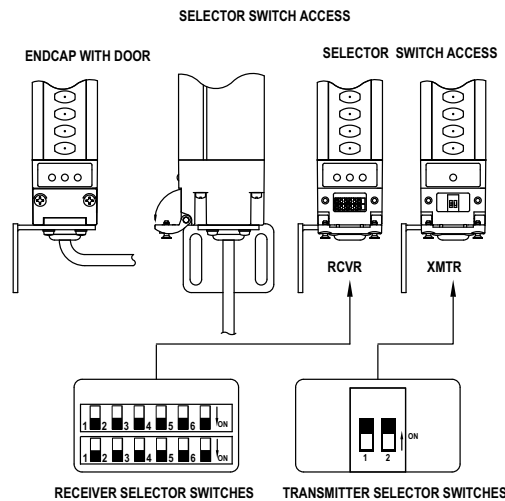

Figure 6-1 MS4800S Selector switches

### 6.2.1 TRANSMITTER SELECTOR SWITCH SETTINGS

Switch Position	Function	Factory Default
1	SCAN CODE	SCAN CODE A
2	MTS	MTS OFF

**NOTE!** MTS is not available/applicable on the 5-pin version of the MS4800, the MTS selector switches **MUST** remain in the OFF position.

Table 6-1 Transmitter Selector Switch Settings

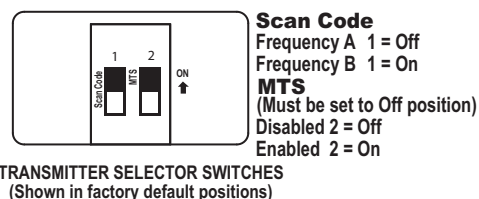

Figure 6-2 Transmitter Selector Switches

6.2.2 RECEIVER SELECTOR SWITCH SETTINGS

Table 6-2 Receiver Selector Switch Settings

Switch A Position	Function	Switch B Position	Function	Factory Default
1	Auto Start or Start/Restart Interlock	1	Auto Start or Start/Restart Interlock	Auto Start (Off)
2	EDM (Always Disabled)	2	EDM (Always Disabled)	Disabled (Off)
3	Scan Code	3	Scan Code	Scan Code A (Off)
4	Floating Blanking 1	4	Floating Blanking 1	Disabled (Off)
5	Fixed Blanking	5	Fixed Blanking	Disable (Off)
6	Program (Non-safety)	6	Range (Non-safety)	Program (toggle) Short Range (Off)

Note: 1. Program and Range are non-safety signals and are not redundant

NOTE! EDM is not available/applicable on the 5-pin version of the MS4800, the EDM selector switches MUST remain in the OFF position.

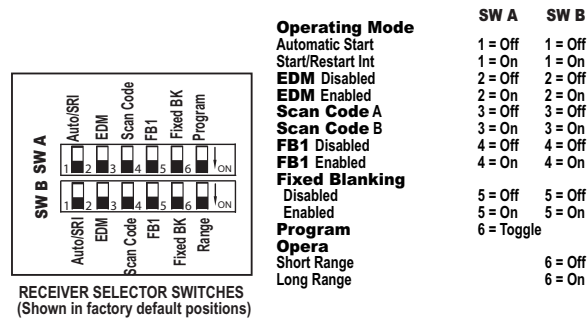

Figure 6-3 Receiver Selector Switch Settings

6.3 OPERATING MODE SELECTION

The Operating mode is selected by setting position 1 of Switches A and B, located on the receiver. Refer to Figure 6-3 Receiver Selector Switch Settings. Any mismatch between the settings of switches A and B will result in an alarm condition. The available operating modes are Automatic Start and Start/Restart Interlock. The 5-pin version should only be used in Automatic Start Mode.

6.4 SELECTING AND PROGRAMMING FIXED BLANKING

Refer to section 4.1.1 Selecting Fixed Blanking with Selector Switches for programming instructions.

NOTE! When Fixed Blanking is active, the amber LED will illuminate to indicate that the system is operating in a less sensitive state.

6.5 SELECTING FLOATING BLANKING

Floating Blanking is activated by setting position 4 of Switches A and B located on the receiver. Refer to Table 6-2 Receiver Selector Switch Settings.

NOTE! When Floating Blanking is active, the amber LED will illuminate to indicate that the system is operating in a less sensitive state.

6.6 SELECTING SCAN CODES

The MS4800S receiver and transmitter offer scan code selection to minimize cross-talk. On the transmitter this is activated by setting position 1. On the receiver this is activated by setting position 3 of switch A and switch B. NOTE: Both receiver and transmitter must be set to the same code.

# 7 OUTPUTS

# 7

## 7.1 SAFETY OUTPUTS

**▲ WARNING!** *This product is designed for use on a 24 VDC, negative ground (protective earth) electrical system only. Never connect the MS4800 system to a positive ground (protective earth) system. With a positive ground (protective earth) wiring scheme, certain simultaneous shorts of both safety outputs may not be detected and the guarded machine may not stop, resulting in severe operator injury.*

The MS4800 system receiver supplies two independent PNP-type, safety outputs to provide run/stop signals to the guarded machine. In the MACHINE RUN state, the safety outputs are electrically conducting and source 625mA of current at 24 VDC. In the MACHINE STOP state, the outputs are not electrically conducting.

# 8 SAFE MOUNTING DISTANCE

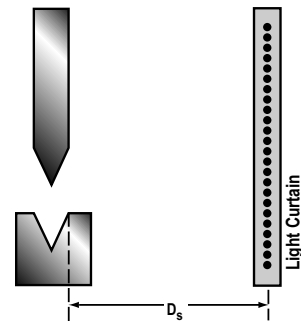

$D_s$  is the minimum safe distance between the light curtain sensing field and the point of operation hazard (pinch point).

**▲ WARNING! Never install an MS4800 system without regard to the safety distance. If the MS4800 system is mounted too close to the point of operation hazard, the machine may not stop in time to prevent an operator injury.**

An MS4800 system must be mounted far enough from the machine danger zone so the machine will stop before a hand or other body part reaches the hazardous area. This distance is called the safety distance. It is a calculated number based on a formula. See *Figure 8-1* for an illustration of the safety distance.

Regardless of the calculated distance, an MS4800 system should never be mounted closer to the point of operation hazard than specified by Table 0-10 in OSHA 1910.217.

*Figure 8-1 Safe Mounting Distance*

## 8.1 US SAFETY DISTANCE FORMULAS

In the United States two formulas exist to properly determine the safety distance. Omron STI recommends the formula provided by the American National Standards Institute (ANSI) which incorporates additional factors when compared to the formula required by OSHA.

The ANSI formula given below is for a normal approach to the light curtain.

$$D_s = K \times (T_s + T_c + T_r + T_{bm}) + D_{pf}$$

Where:

$D_s$  = minimum safety distance, in inches, between the MS4800 detection zone and the nearest point of operation hazard.

$K$  = hand speed constant in inches per second. The ANSI standard value is 63 inches/second which assumes the operator starts a hand motion toward the point of operation from rest. According to ANSI B11.19-2003, the following factors should be considered when determining  $K$ :

- a) Hand and arm movement
- b) Twisting of the body or shoulder, or bending at the waist,
- c) Walking or running.

One of the accepted values for  $K$  is the hand speed constant (it is usually considered as the horizontal motion of the hand and arm while seated). Its common value is 63 in/s (1.6 m/s) although other values (typically greater) are also used. The hand speed constant does not include other body movements, which can affect the actual approach speed. Consideration of the above factors should be included when determining the speed constant for a given application.

$T_s$  = the stop time of the press (or machine) in seconds, measured from the final de-energized control element. Measured at maximum closing velocity.

$T_c$  = the response time, in seconds, of the press or machine control circuit to activate the machine's brake.

**NOTE!**  $T_s + T_c$  is usually measured together by a stop time measuring device.

$T_r$  = the response time of the MS4800 system, in seconds. This response time is given in *Table 13-1*.

**▲ WARNING!** When using an Omron STI RM-X, RM-1 or RM-2AC with the MS4800 system, add 8ms to the response times stated in *Table 13-1*.

$T_{bm}$  = the additional stopping time, in seconds, allowed by the brake performance monitor before it detects stop time deterioration.

The  $T_{bm}$  factor allows consideration for brake wear, adding extra stop time allowed by the brake monitor. Therefore,  $T_{bm}$  = Brake monitor set point - ( $T_s + T_c$ ).

**NOTE!** If the guarded machine is not equipped with a stop time performance monitor, a percentage increase factor should be applied to the stop time of the machine to allow for braking system wear. Contact your machine manufacturer for information.

$D_{pf}$  = This is related to the minimum object sensitivity of the MS4800 system. By knowing the minimum object sensitivity, S, of the MS4800 system,  $D_{pf}$  is read directly from *Table 4-5*, *Table 4-6*, *Table 4-7* or *Table 4-8* depending on the minimum object sensitivity of the system being installed.

## 8.2 EUROPEAN SAFETY DISTANCE FORMULAS

The following discussion is based on standard EN999 and applies to light curtains used in industrial environments.

### 8.2.1 SAFETY DISTANCE FORMULA FOR SYSTEMS WITH A MINIMUM OBJECT RESOLUTION OF 40 MM OR LESS

When the minimum object resolution of the system is 40 mm or less, use the following formula:

$$S = (K \times T) + C$$

where:

S = the minimum distance in millimeters, from the danger zone to the detection point, line, plane or zone.

$$K = 2000 \text{ mm/s}$$

T = the overall system stopping performance in seconds.

$$T = t_1 + t_2$$

$t_1$  = response time of the safety light curtain in seconds. This response time is given in *Table 13-1*.

$t_2$  = maximum stopping time of the machine in seconds.

$$C = 8(d - 14 \text{ mm}), \text{ but not less than zero.}$$

d = the minimum object resolution of the MS4800 system in millimeters. therefore,

$$S = (2000 \text{ mm/s} \times T) + 8(d - 14 \text{ mm})$$

This formula applies for all minimum distances of S up to and including 500 mm. The minimum value of S shall not be less than 100 mm.

If S is found to be greater than 500 mm using the formula above, then the formula below can be used. In this case the minimum value of S shall not be less than 500 mm.

$$S = (1600 \text{ mm/s} \times T) + 8(d - 14 \text{ mm})$$

### 8.2.2 SAFETY DISTANCE FORMULA FOR SYSTEMS WITH A MINIMUM OBJECT RESOLUTION GREATER THAN 40 MM

When the minimum object resolution of the system is greater than 40 mm, use the following formula:

$$S = (K \times T) + C$$

where:

S = the minimum distance in millimeters, from the danger zone to the detection point, line, plane or zone.

K = 1600 mm/s

T = the overall system stopping performance in seconds.

$$T = t_1 + t_2$$

$t_1$  = response time of the safety light curtain in seconds. This response time is given in *Table 13-1*.

$t_2$  = maximum stopping time of the machine in seconds.

C = 850 mm.

i.e.:

$$S = (1600 \text{ mm/s} \times T) + 850 \text{ mm}$$

### **8.2.3** *FACTORS AFFECTING THE SAFETY DISTANCE FORMULA*

When light curtains are used for machine initiation, their minimum object resolution must be 30 mm or smaller (based on EN 999, other standards may vary). In this case the formula given in section 8.2.1 applies except that the minimum distance S shall be greater than 150 mm.

For parallel approach the formula for C becomes:

$$C = 1200 \text{ mm} - (0.4 \times H), \text{ but not less than } 850 \text{ mm}$$

H = the height of the detection zone above the floor in mm.

## 9 INSTALLATION

### 9.1 REFLECTIVE SURFACE INTERFERENCE

A reflective surface adjacent to the detection zone can deflect the optical beam and may cause an obstruction in the zone not to be detected. (See *Figure 9-1* through *Figure 9-5*.) The reflective surface may be part of the machine, mechanical guard or workpiece. Therefore, a minimum distance ( $d$ ) must exist between the reflective object and the center line of the detection zone. The Test Procedure (Appendix B) must be used to test for this condition.

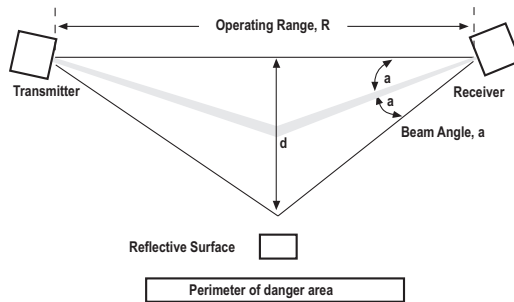

*Figure 9-1 Worst Case Alignment Example*

The interruption is clearly detected. The reflective object is outside of the beam angle.

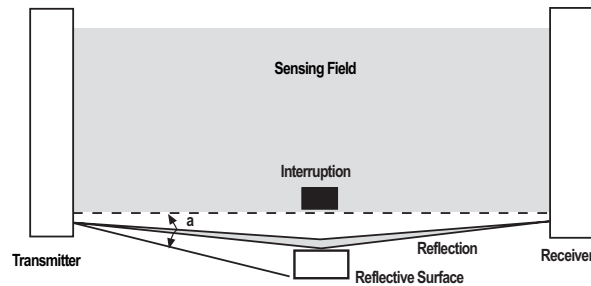

*Figure 9-2 Unsafe Mounting Example (1)*

The interruption is not detected because of the reflection. The reflective object is inside the beam angle.

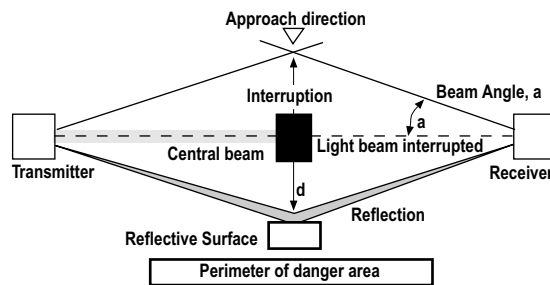

*Figure 9-3 Unsafe Mounting Example (2)*

Interruption is not detected because of the reflection. Reflective surface interference may also appear above and below the sensing field

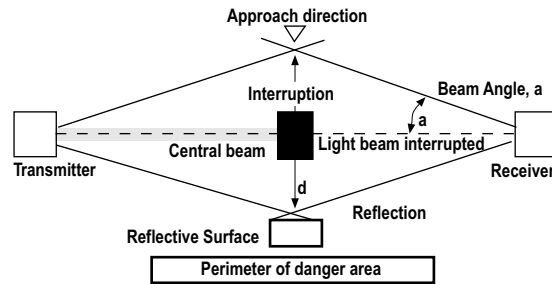

Figure 9-4 Correct Mounting Example with Proper Alignment

This example shows the minimum distance from the reflective surface,  $d$ , to one side of the beam center line.

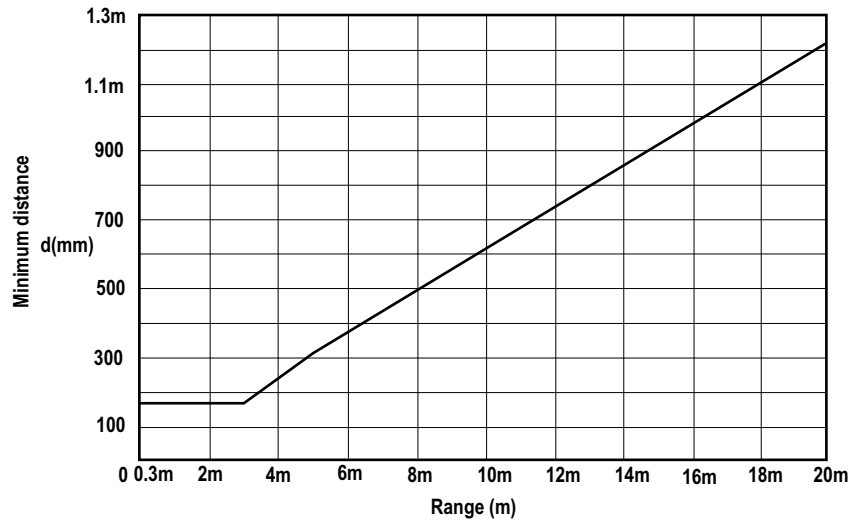

Figure 9-5 Minimum Distance from a Reflective Surface as a Function of Range

## 9.2 CROSS TALK MITIGATION

To mitigate interference from other light curtains, the MS4800 has two possible scan codes, A and B. The transmitter and receiver units must be set to the same scan code for the receiver to enter the MACHINE RUN state.

### 9.3 GENERAL MOUNTING CONSIDERATIONS

#### 9.3.1 ADDITIONAL GUARDING

Areas of access to the point of hazardous operation not guarded by the MS4800 system must be protected by suitable means such as a fixed barrier guard, an interlocked guard or a safety mat. See *Figure 9-6*.

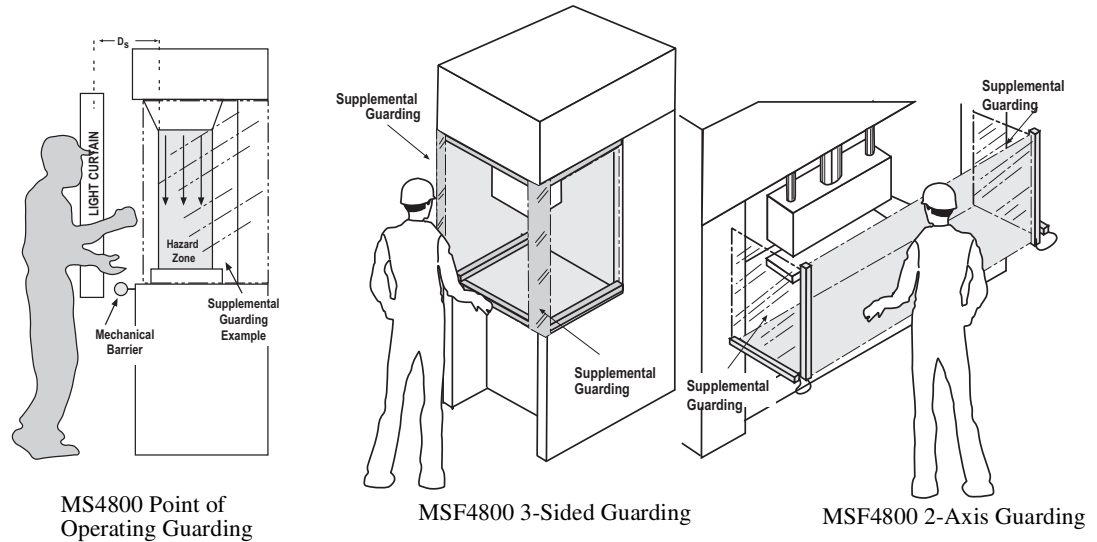

*Figure 9-6 Correct Light Curtain Installation Example*

#### 9.3.2 ADDED MOUNTING RIGIDITY

It is recommended that when installing a MS4800 larger than 1000mm (40 in) in length, you use an additional mounting bracket. This is to be installed using the T-slot on the backside of the transmitter and receiver.

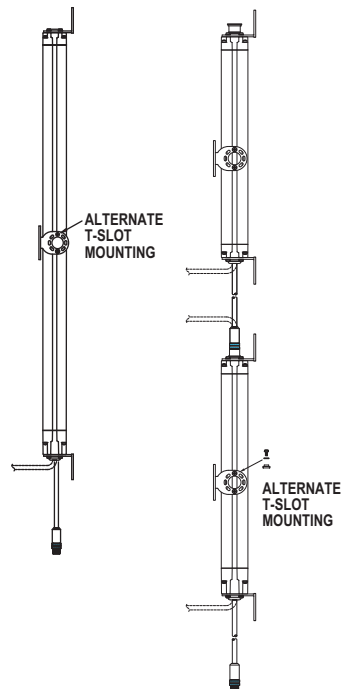

*Figure 9-7 Adding Mounting Bracket*

**9.3.3** *INSTALLATION OF MULTIPLE SYSTEMS*

When two or more MS4800 systems with the same scan code are mounted in close proximity and in alignment with each other, precautions should be taken to avoid one system interfering with another. This can be corrected by mounting the transmitters and receivers back-to-back or stacked.

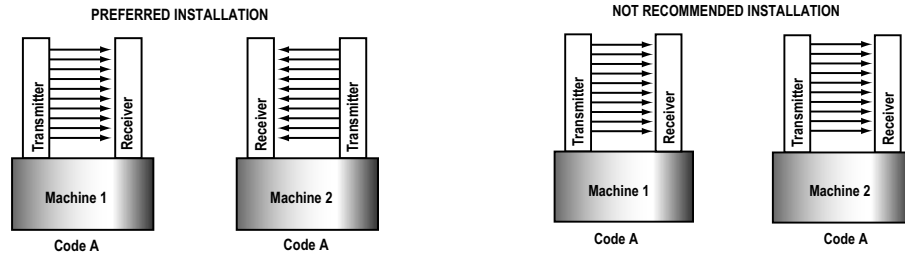

*Figure 9-8 Multiple Light Curtain Installation Configurations*

The scan coding feature of the MS4800 system allows for placement of systems in close proximity and in line with each other. The distinctive coding of the beams provide for unique operation of a system while in view of another system with a different scan code. Two unique codes are available on the MS4800.

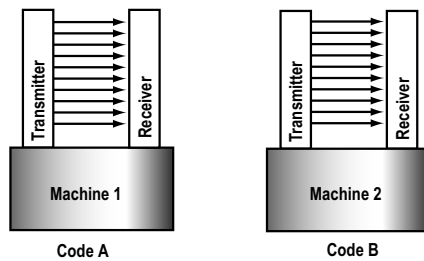

*Figure 9-9 Multiple Light Curtain Installation Configurations using Scan Codes*

**9.3.4** *DETECTION ZONE*

The system detection zone is delineated by the inside edge of the transmitter and receiver endcaps. The area outside these marks is not protected. Position the system so that it is only possible to access the danger point through the detection zone.

**9.3.5** *ALIGNMENT*

Physical alignment of the transmitter and receiver is easiest when the system is in the automatic start operating mode with Fixed Blanking inactive. The units should be in the same plane and at equal height.

The Individual Beam Indicators will light when a beam is out of alignment. See Section 5.1 -- *Individual Beam Indicators* for details.

**9.3.6** *INPUT POWER REQUIREMENTS*

The system operates directly from 24 VDC  $\pm 20\%$ . Power to the system must come from a 24VDC SELV power supply which meets the voltage interruptions and dip requirements of IEC 61496-1 (per section 4.3.22 and 5.4.3.2) and IEC 60204-1 (per section 4.3.3) , Omron STI part number 42992 or equivalent.

**9.3.7** *REQUIREMENTS FOR PERIMETER GUARDING*

In perimeter guarding applications the MS4800 system detection zone is placed around the outside perimeter of a guarded machine or robot. This placement leaves space for personnel to stand between the detection zone and the hazardous machine.

In this case, the guarded machine must only be restarted using a switch located outside and with a full view of, the area of hazardous motion. Operation of the MS4800 system in theStart/Restart Interlock operating mode is suitable for perimeter guarding.

**9.3.8** *MARKING MINIMUM OBJECT RESOLUTION*

Serial number labels on the transmitter and receiver indicate 4 possible minimum object resolutions. During installation, use a permanent marker to obscure the object resolutions not set. This will depend on whether no floating blanking, 1-beam or 2-beam floating blanking is set. See section 5.3.1 for information.

**9.3.9** *PRESENCE SENSING DEVICE INITIATION*

Using the light curtain to initiate a machine cycle after an object is removed from the sensing area is called Presence Sensing Device Initiation (PSDI). Use of PSDI places additional requirements on the guarding and safety controls. It can restrict advanced light curtain features such as Floating Blanking and Fixed Blanking. Contact Omron STI for further information. Good sources of reference for PSDI include: ANSI RIA 15.06-1999, OSHA 1910.217(h), and ANSI B11.2-1995 (R2005).

# 10 CONNECTING TO THE MACHINE CONTROL CIRCUIT

# 10

- ▲ **WARNING!** *This product is designed for use on a 24 VDC, negative ground (protective earth) electrical system only. Never connect the MS4800 system to a positive ground (protective earth) system. With a positive ground (protective earth) wiring scheme, certain simultaneous shorts of both safety outputs may not be detected and the guarded machine may not stop, resulting in severe operator injury.*
- ▲ **WARNING!** *Never use only a single safety output to control the machine. Should this single output fail, the machine may not stop, resulting in severe operator injury. The machine must be connected using both safety outputs.*

### 10.1 CONNECTING TO A SAFETY MONITORING DEVICE

The wiring from the MS4800 system to the machine control circuit must be control reliable as described in ANSI B11.19-2003. Normally PLCs are not designed to be control reliable. Safety devices such as the MS4800 system should not depend on a PLC to stop a guarded machine.

However, safety related monitoring devices are now available. See *Figure 10-1* for connection to such a device. Note that all safety inputs are directed to the monitoring device which also performs the EDM monitoring function.

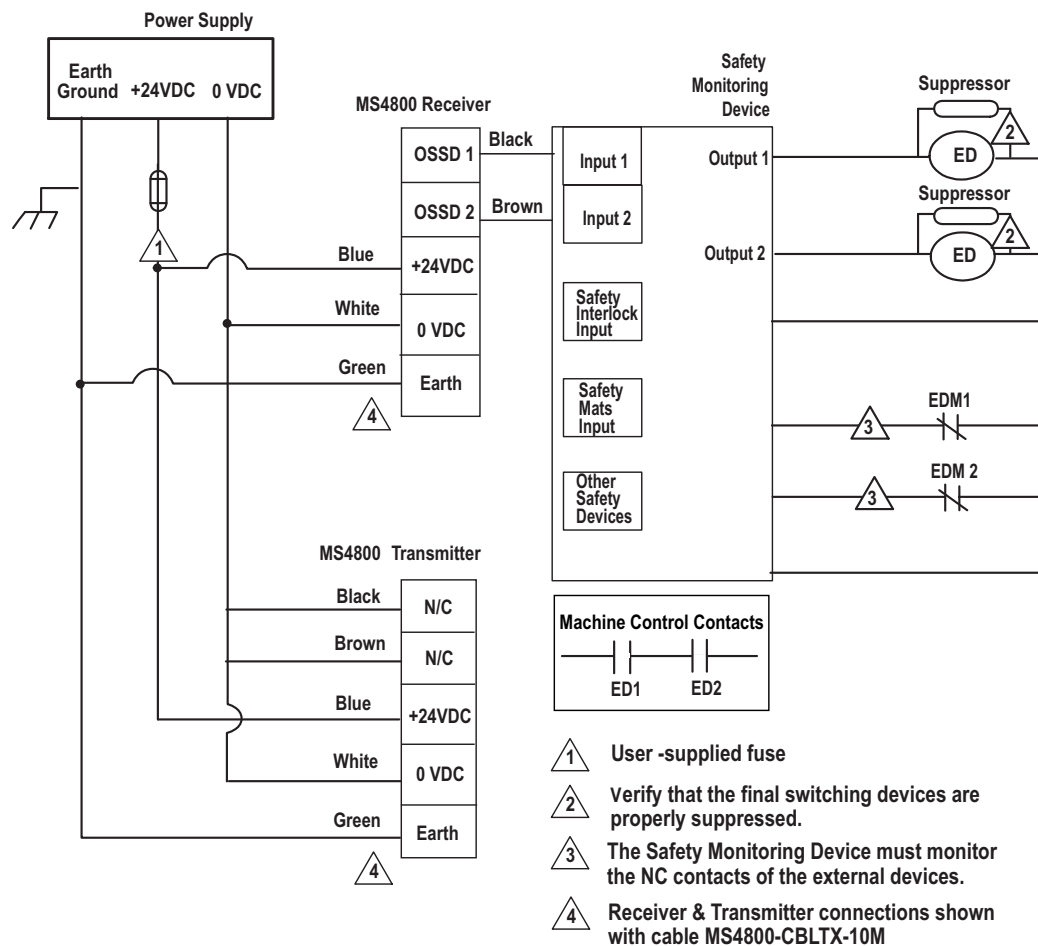

Figure 10-1 Connecting to a Safety Monitoring Device

## 10.2 CONNECTING VIA AN RM-1 MODULE

The Omron STI RM-1 Module provides force-guided relay outputs for machine control. OSSD Safety outputs 1 and 2 are connected to the RM-1 and provide the power necessary to energize its relays. See *Figure 10-2* for the preferred connection method using the RM-1. The auxiliary non-safety output of the MS4800 system can be used to signal light curtain status to a PLC.

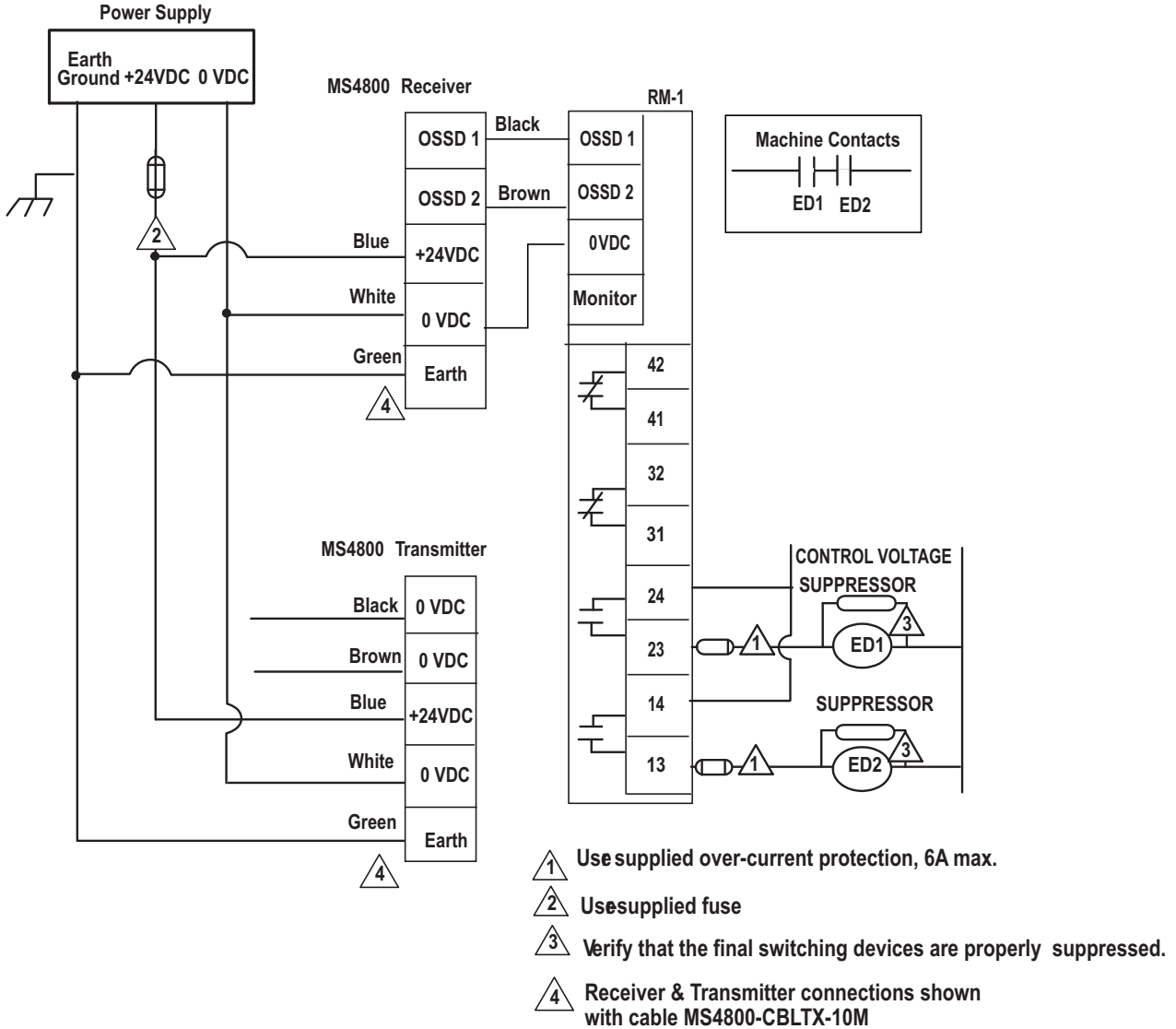

Figure 10-2 Connecting via an RM-1 Module

### 10.3 CONNECTING VIA AN RM-2AC MODULE

The Omron STI RM-2AC module provides force-guided relay outputs for machine control as well as a convenient location to terminate all outputs and inputs from MS4800 system. See *Figure 10-3* for the preferred connection method using the RM-2AC.

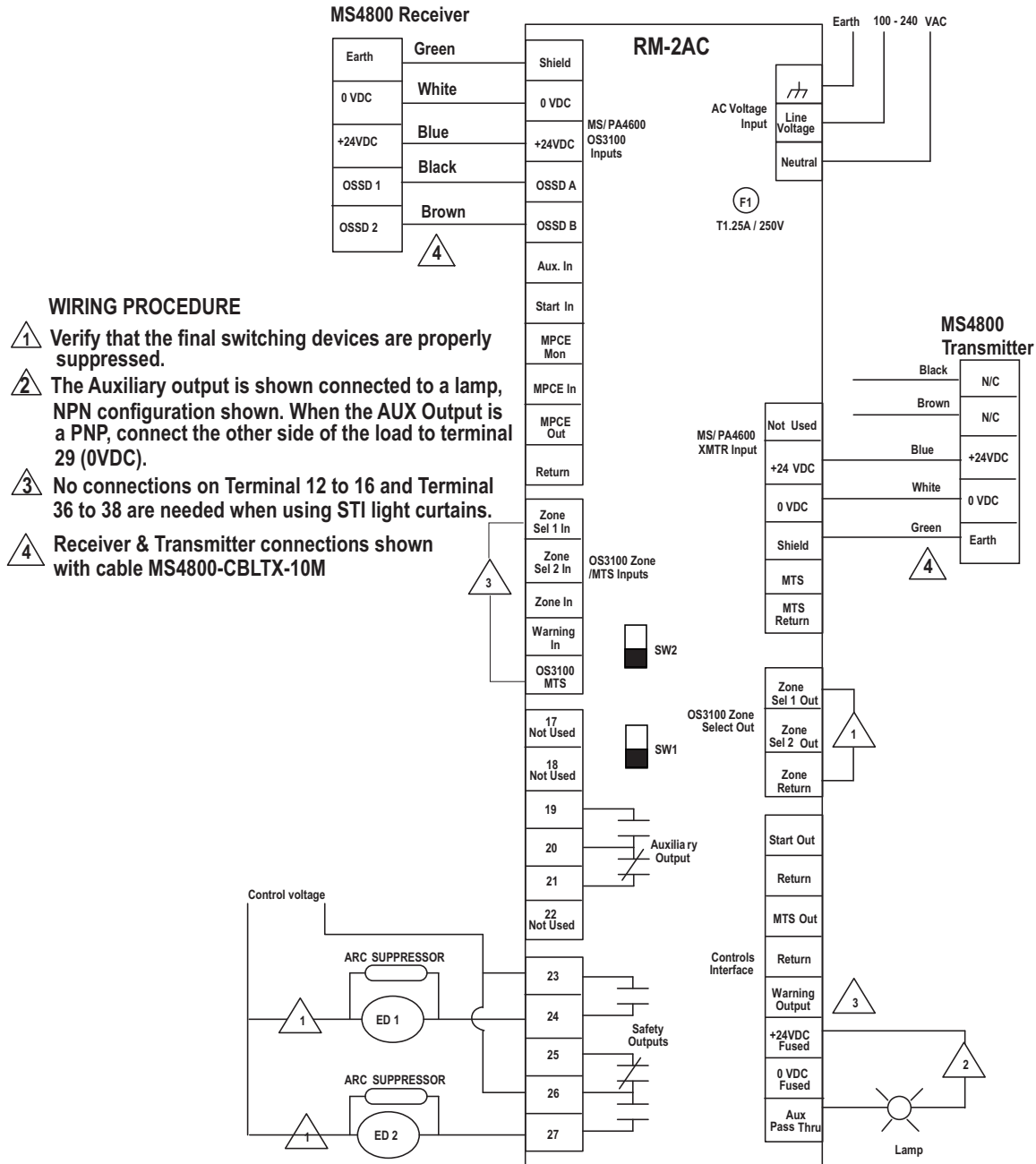

Figure 10-3 Connecting via an RM-2AC Module

### 10.4 CONNECTING VIA TWO FORCE-GUIDED RELAYS

FGR series relays provides force-guided relay outputs for machine control. See *Figure 10-4* for the preferred connection method using two force-guided relays.

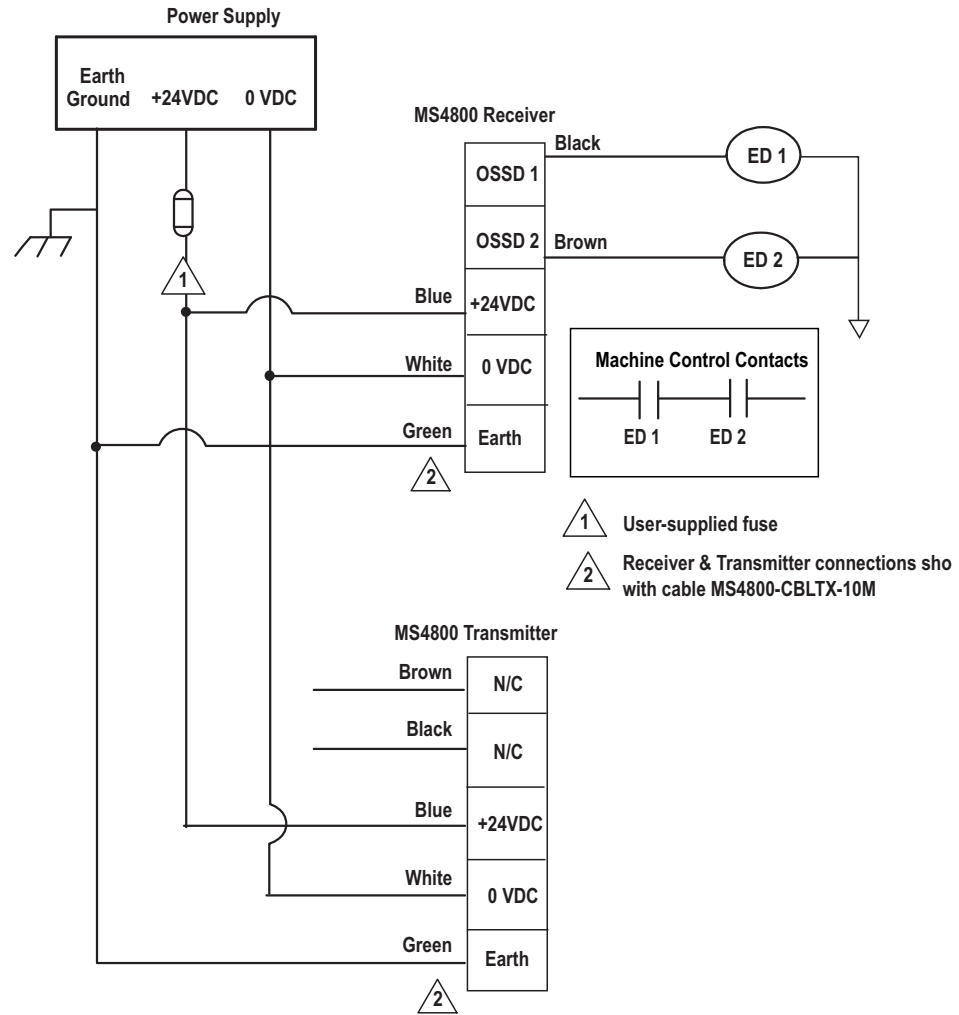

Figure 10-4 Connecting Via Two Force-guided Relays

### 10.5 CONNECTING VIA AN RM-2AC-IP

- EDM (SW1): select either internal (INT) or external (EXT). By default, this is set to INT.

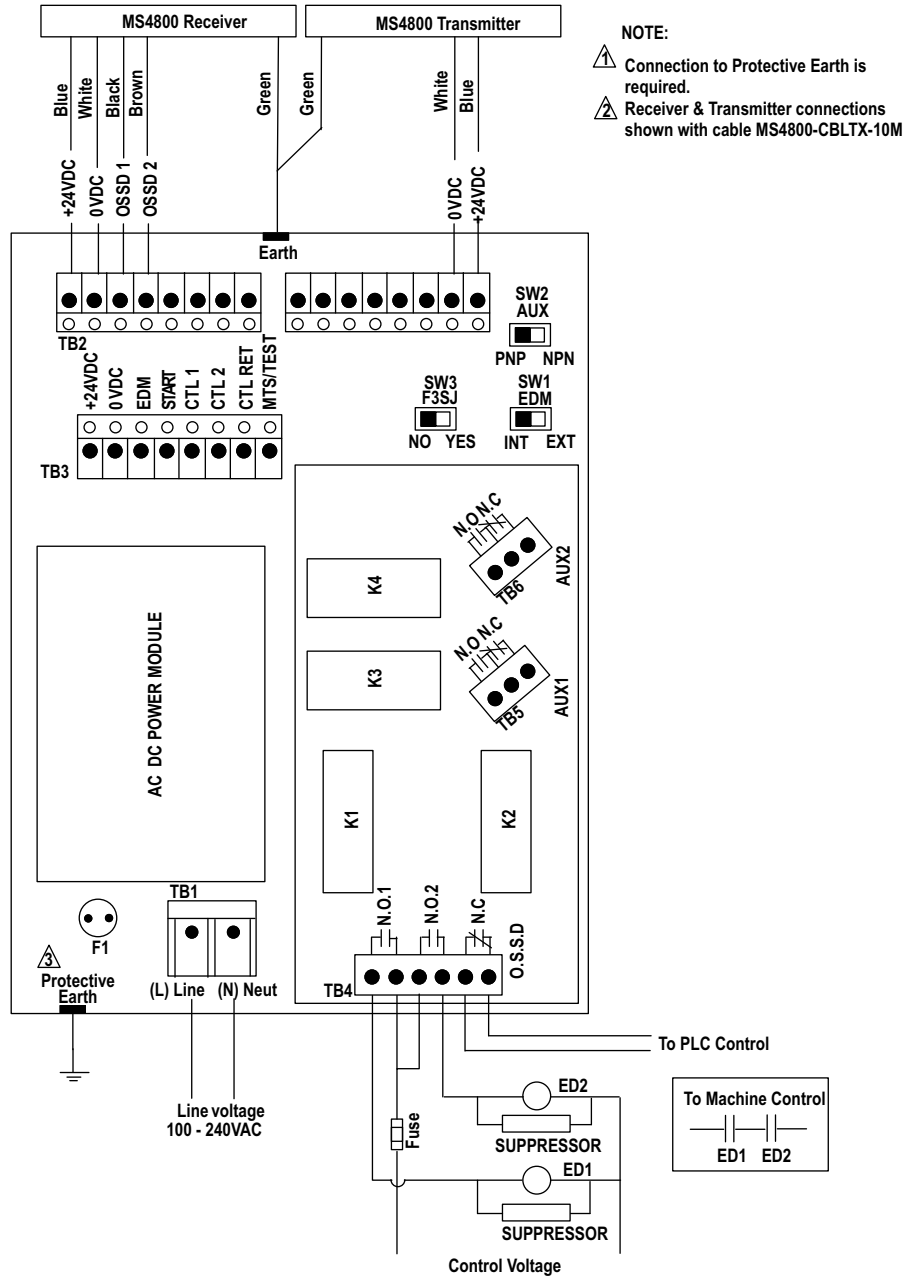

Figure 10-5 Connecting Via An RM-2AC-IP Module

# 11 CHECKOUT AND TEST PROCEDURES

# 11

## 11.1 CHECKOUT PROCEDURE

Once the MS4800 system has been configured, mounted, aligned and properly connected to the machine control system, the initial Checkout Procedure detailed in Appendix A must be performed by qualified personnel. A copy of the checkout results should be kept with the machine records.

## 11.2 TEST PROCEDURE

**▲ WARNING!** *The tests outlined in the Test Procedure in Appendix B must be performed at installation, according to the employer's regular inspection program and after any maintenance, tooling change, set up, adjustment, or modification to the MS4800 system or the guarded machine. Where a guarded machine is used by multiple operators or shifts, it is suggested that the test procedure be performed at each shift or operator change. Testing ensures that the light curtain and the machine control system work properly to stop the machine. Failure to test properly could result in serious injury to personnel.*

The Test Procedure must be performed by qualified personnel. To test the MS4800 system with Fixed Blanking and Floating Blanking disabled, use the Omron STI-supplied test object. For applications where Fixed Blanking or Floating Blanking are enabled, see *Table 4-6* to determine the proper size test object.

When using an MS4800 system set for Automatic Start Mode operation, in conjunction with an RM-1 or RM-2AC relay module, it is necessary to verify that the RM-1 or RM-2AC outputs can properly change state by causing an intentional beam break at least every change of shift or 24 hours of operation.

## 11.3 USING THE TEST OBJECT

When using the test object, guide it through the detection zone as shown below.

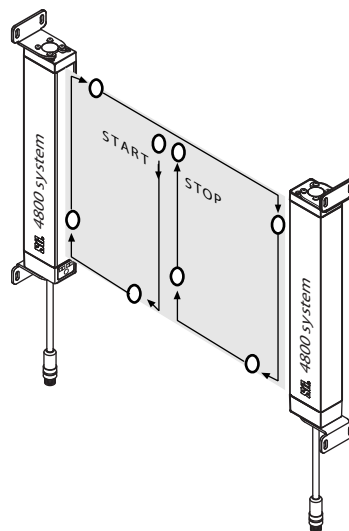

Figure 11-1 Test Object Pattern

## 12 CLEANING

# 12

Accumulation of oil, dirt and grease on the front window of the MS4800 transmitter and receiver can effect the system operation. Clean the window with a mild detergent or glass cleaner. Use a clean, soft, lint-free cloth. Painted MS4800 surfaces may be cleaned with a mild de-greasing cleaner or detergent.

# 13 SPECIFICATIONS AND ADDITIONAL INFORMATION

# 13

## 13.1 SYSTEM SPECIFICATIONS

Table 13-1 System Specifications

<b>Performance:</b>	
Protective Height	240-1800mm (14/20mm res.), 280-2120mm (30mm Res.), 360-2040mm (40mm Res.)
Object Resolution	14, 20, 30, and 40mm
Operating Range	14mm resolution - 0.3 to 7m (1 to 23 ft.) default; 0.3 to 3m (1 to 10 ft.) 20, 30 and 40mm resolution - 0.3 to 20m (1 to 65 ft.) default; 0.3 to 8m (1 to 26 ft.)
Effective Aperture Angle	± 2.5° maximum, transmitter and receiver at operating range greater than 3 meters per IEC 61496-2.
Safety Output	Two PNP, each output sourcing 625 mA @ 24 VDC, short circuit protected. (See note 2)
Response Time	See <i>Table 13-2</i>
Light Source	Infrared Light Emitting Diode, 880 nm
Transmitter Indicator Lights	Active (Yellow)
Receiver Indicator Light	MACHINE RUN/Stop (green/red), INTERLOCK/Alarm (Yellow), Blanking (amber)
<b>Electrical:</b>	
Power Input Transmitter:	24 VDC ± 20% 285 mA max.
Power Input Receiver:	24 VDC ± 20% 1.7A max. (receiver 450mA + OSSD1 625 mA max. + OSSD2 625 mA max. ). (See note 1)
Power Supply	Must meet requirements of IEC 60204-1 and IEC 61496. Omron STI part number 42992 or equivalent. (See note 1 ).
<b>Mechanical:</b>	
Construction	Polyurethane powder painted aluminum
Cable length	Available in 10, 15, and 30 m lengths, unshielded. (See note 3).
Wiring Connections	M12 connectors: 5-pin receiver and 5-pin transmitter.
<b>Environmental:</b>	
Enclosure rating	IP65
Operating Temperature	-10 to 55° C (14 to 131 F)
Storage Temperature	-25 to 75° C (-14 to 167 F)
Relative Humidity	95% maximum, non-condensing
Vibration	10 - 55Hz maximum on all 3 axes
Shock	10g for 0.016 seconds; 1,000 shocks for each of three axes

Conformity/Approvals	
Conforming to standards	ANSI R15.6-1999, ANSI B11.19-2003, OSHA 1910.217(c).
Other approvals:	All systems have been EC type examined to the requirements of IEC 61496-1, -2 for a Type 4 ESPE. TUV Registration No. BB600166650001. UL61496-1 & -2. IEC 61508 (SIL3)
	Specifications subject to change

**Note 1:** The system operates directly from 24 VDC  $\pm 20\%$ . Power to the system must come from a 24VDC SELV power supply which meets the voltage interruptions and dip requirements of IEC 61496-1 (per section 4.3.2.2 and 5.4.3.2) and IEC 60204-1 (per section 4.3.3), Omron STI part number 42992 or equivalent. The power supply size is dependent on the total current required by two solid-state safety outputs and the auxiliary output should not exceed 1.35 A. Total system current requirements is the sum of transmitter (285mA), receiver (450mA), OSSD1 (625mA), OSSD2 (625mA).

**Note 2:** 24 VDC is nominal. Actual voltage is dependent upon supply,  $V = V_{\text{supply}} - 1V$ .

**Note 3:** When using a Omron STI-supplied 30 meter receiver cable the total load current is limited to 1.2A at 24V (nominal). See when using customer supplied cables.

**Table 13-2 Response Time of MS/MSF4800 System**

One Segment System			Two Segment System		
Minimum Beam Count	Maximum Beam Count	Response Time (ms)	Minimum Beam Count	Maximum Beam Count	Response Time (ms)
		Normal			Normal
0	16	14	0	65	23
17	71	23	66	120	32
72	126	32	121	174	41
127	180	41	175	229	50
181	235	50	230	256	59
236	256	59			
Three Segment System			Four Segment System		
Minimum Beam Count	Maximum Beam Count	Response Time (ms)	Minimum Beam Count	Maximum Beam Count	Response Time (ms)
		Normal			Normal
0	59	23	0	53	23
60	114	32	54	108	32
115	168	41	109	162	41
169	223	50	163	217	50
224	256	59	218	256	59

Note: Refer to Section 13 -- *Specifications and Additional Information* to determine the number of beams in your system.

### 13.2 CABLE LENGTHS (CUSTOMER SUPPLIED CABLES)

The table below lists the maximum specified lengths and wire gauges of the MS4800 input & output signals.

**Table 13-3 MS4800 Input & Output Signal Cable Lengths**

MS4800	Signal Names	Wire Gauge	Specified Maximum Length
MS4800 Receiver	OSSD 1 & 2 Outputs	22 AWG (0.32mm <sup>2</sup> ) wire	300mA load: 45 meter (147 ft) 625mA: 22 meter (72 ft)
	24 VDC Input Power & Return	20 AWG (0.52mm <sup>2</sup> ) wire	1.8 Amp load: 12.5 meter (41 ft) 1 Amp load: 22 meter (72 ft)
MS4800 Transmitter	24 VDC Input Power & Return	22 AWG (0.32mm <sup>2</sup> ) wire	0.3 Amp: 47 meter (150 ft)

**13.3 MINISAFE MS4800 DIMENSIONAL DRAWINGS**

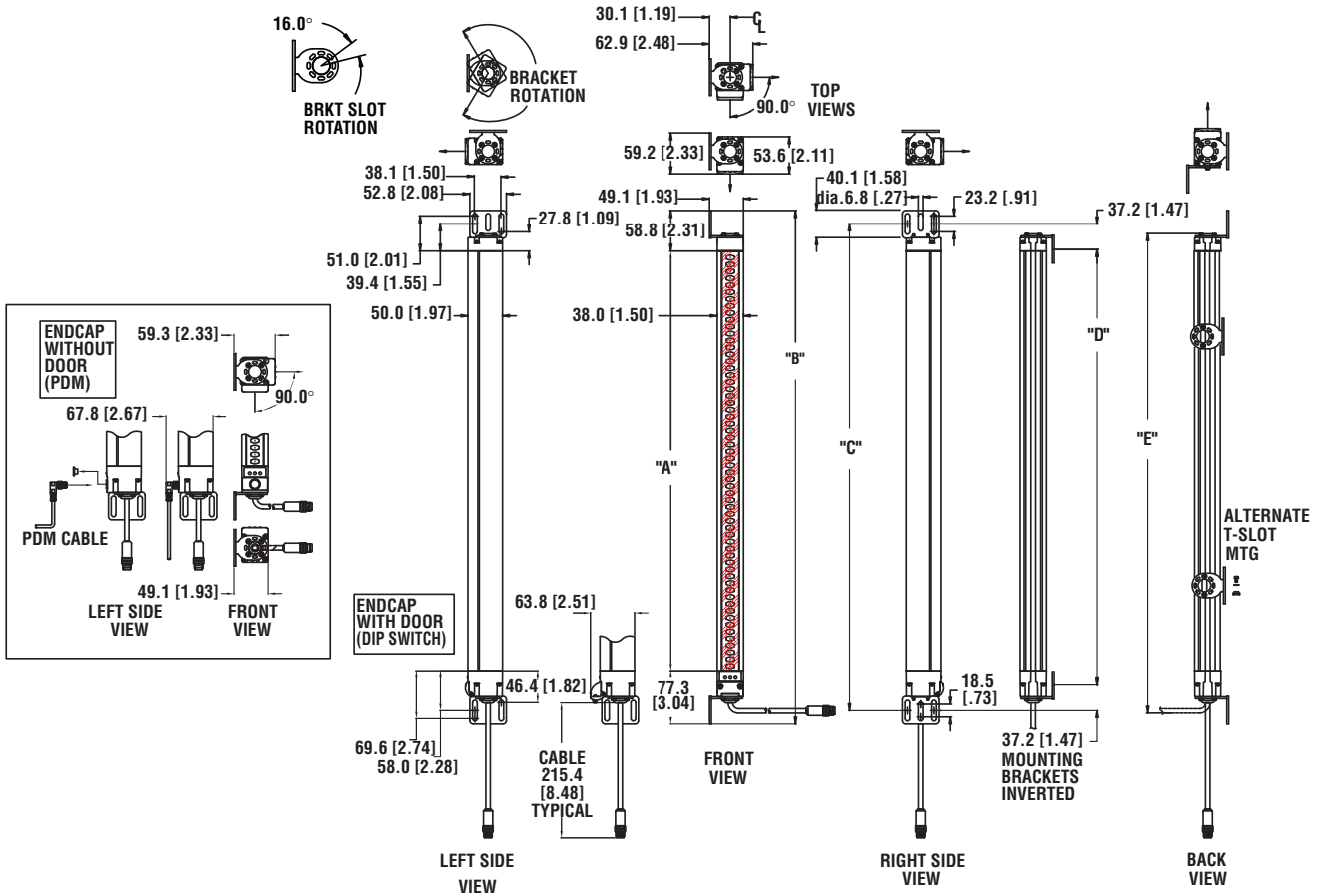

Figure 13-1 MS4800 Dimensional Drawing

Table 13-4 MS4800-14/20 Transmitter and Receiver Dimensions

	280mm	320mm	360mm	400mm	440mm	480mm	520mm	560mm
<b>A</b>	284.4/11.2	324.8/12.8	364.5/14.4	404.2/15.9	443.9/17.5	484.3/19.1	523.4/20.6	563.7/22.2
<b>B</b>	420.4/16.6	460.8/18.1	500.5/19.7	540.2/21.3	579.9/22.8	620.3/24.4	659.4/26.0	699.7/27.6
<b>C</b>	381.7/15.0	422.1/16.6	461.8/18.2	501.5/19.7	541.2/21.3	581.6/22.9	620.7/24.4	661.0/26.0
<b>D</b>	307.3/12.1	347.7/13.7	387.4/15.3	427.1/16.8	466.8/18.4	507.2/19.9	546.3/21.5	586.6/23.1
<b>E</b>	371.3/14.6	411.7/16.2	451.4/17.8	491.1/19.3	530.8/20.9	571.2/22.5	610.3/24.0	650.6/25.6

	600mm	640mm	680mm	720mm	760mm	800mm	840mm	880mm
<b>A</b>	604.1/23.8	643.9/25.4	683.6/26.9	724.0/28.5	762.0/30.0	803.5/31.6	843.4/31.6	882.8/34.8
<b>B</b>	740.1/29.1	779.9/30.7	819.6/32.3	860.0/33.9	898.0/35.4	939.5/37.0	979.8/38.6	1018.8/40.1
<b>C</b>	701.4/27.6	741.2/29.2	780.9/30.7	821.3/32.3	859.3/33.8	900.8/35.5	941.1/37.1	980.1/38.6
<b>D</b>	627.0/24.7	666.8/26.3	706.5/27.8	746.9/29.4	784.9/30.9	826.4/32.5	866.7/34.1	905.7/35.7
<b>E</b>	691.0/27.2	730.8/28.8	770.5/30.3	810.9/31.9	848.9/33/42	890.4/35.1	930.7/36.6	969.7/38.2

	920mm	960mm	1000mm	1040mm	1080mm	1120mm	1160mm	1200mm
<b>A</b>	922.5/36.3	963.6/37.9	1002.6/39.5	1042.9/41.1	1083.9/42.7	1122.3/44.2	1162.7/45.8	1203.8/47.4
<b>B</b>	1058.5/41.7	1099.6/43.3	1138.6/44.8	1178.9/46.4	1219.9/48.0	1258.3/59.4	1298.7/51.1	1339.8/52.7
<b>C</b>	1019.8/40.2	1060.9/41.8	1099.9/43.3	1140.2/44.9	1181.2/46.5	1219.6/48.0	1260.0/49.6	1301.1/51.2
<b>D</b>	945.4/37.2	986.5/38.8	1025.5/40.4	1065.8/42.0	1106.8/43.6	1145.2/45.1	1185.6/46.7	1226.7/48.3
<b>E</b>	1009.4/39.7	1050.5/41.4	1089.5/42.9	1129.8/44.5	1170.8/46.1	1209.2/47.6	1249.6/49.2	1290.7/50.8

	1240mm	1280mm	1320mm	1360mm	1400mm	1440mm	1480mm	1520mm
<b>A</b>	1242.1/48.9	1281.8/50.5	1323.6/52.1	1362.0/53.6	1401.7/55.2	1443.4/56.8	1481.8/58.3	1521.5/59.9
<b>B</b>	1378.1/54.3	1417.8/55.8	1459.6/57.5	1498.0/59.0	1537.7/60.5	1579.4/62.2	1617.8/63.7	1657.5/65.3
<b>C</b>	1339.4/52.7	1379.1/54.3	1420.9/55.9	1459.3/57.5	1499.0/59.0	1540.7/60.7	1579.1/62.2	1618.8/63.7
<b>D</b>	1265.0/49.8	1304.7/51.4	1346.5/53.0	1384.9/54.5	1424.6/56.1	1466.3/57.7	1504.7/59.2	1544.4/60.1
<b>E</b>	1329.0/52.3	1368.7/53.9	1410.5/55.5	1448.9/57.0	1488.6/58.6	1530.3/60.2	1568.7/61.8	1608.4/63.3

	1560mm	1600mm	1640mm	1680mm	1720mm	1760mm	1800mm
<b>A</b>	1563.3/61.6	1600.9/63.0	1641.3/64.6	1683.1/66.3	1720.8/67.8	1760.5/69.3	1802.9/71.0
<b>B</b>	1699.3/66.9	1736.9/68.4	1777.3/70.0	1819.1/71.6	1856.8/73.1	1896.5/74.7	1938.9/76.3
<b>C</b>	1660.6/65.4	1698.2/66.9	1738.6/68.5	1780.4/70.0	1818.8/71.6	1857.8/73.1	1900.2/74.8
<b>D</b>	1586.2/62.5	1623.8/63.9	1664.2/65.5	1706.0/67.2	1743.7/68.7	1783.4/70.2	1825.8/71.9
<b>E</b>	1650.2/65.0	1687.8/66.5	1728.2/68.0	1770.0/69.7	1807.7/71.2	1847.4/72.7	1889.8/74.4

**Table 13-5 MS4800-30 Transmitter and Receiver Dimensions**

	280mm	320mm	360mm	400mm	440mm	480mm	520mm	560mm
<b>A</b>	284.4/11.2	324.8/12.8	364.5/14.4	404.2/15.9	443.9/17.5	484.3/19.1	523.4/20.6	563.7/22.2
<b>B</b>	420.4/16.6	460.8/18.1	500.5/19.7	540.2/21.3	579.9/22.8	620.3/24.4	659.4/26.0	699.7/27.6
<b>C</b>	381.7/15.0	422.1/16.6	461.8/18.2	501.5/19.7	541.2/21.3	581.6/22.9	620.7/24.4	661.0/26.0
<b>D</b>	307.3/12.1	347.7/13.7	387.4/15.3	427.1/16.8	466.8/18.4	507.2/19.9	546.3/21.5	586.6/23.1
<b>E</b>	371.3/14.6	411.7/16.2	451.4/17.8	491.1/19.3	530.8/20.9	571.2/22.5	610.3/24.0	650.6/25.6

	600mm	640mm	680mm	720mm	760mm	800mm	840mm	880mm
<b>A</b>	604.1/23.8	643.9/25.4	683.6/26.9	724.0/28.5	762.0/30.0	803.5/31.6	843.4/31.6	882.8/34.8
<b>B</b>	740.1/29.1	779.9/30.7	819.6/32.3	860.0/33.9	898.0/35.4	939.5/37.0	979.8/38.6	1018.8/40.1
<b>C</b>	701.4/27.6	741.2/29.2	780.9/30.7	821.3/32.3	859.3/33.8	900.8/35.5	941.1/37.1	980.1/38.6
<b>D</b>	627.0/24.7	666.8/26.3	706.5/27.8	746.9/29.4	784.9/30.9	826.4/32.5	866.7/34.1	905.7/35.7
<b>E</b>	691.0/27.2	730.8/28.8	770.5/30.3	810.9/31.9	848.9/33/42	890.4/35.1	930.7/36.6	969.7/38.2

	920mm	960mm	1000mm	1040mm	1080mm	1120mm	1160mm	1200mm
<b>A</b>	922.5/36.3	963.6/37.9	1002.6/39.5	1042.9/41.1	1083.9/42.7	1122.3/44.2	1162.7/45.8	1203.8/47.4
<b>B</b>	1058.5/41.7	1099.6/43.3	1138.6/44.8	1178.9/46.4	1219.9/48.0	1258.3/50.4	1298.7/51.1	1339.8/52.7
<b>C</b>	1019.8/40.2	1060.9/41.8	1099.9/43.3	1140.2/44.9	1181.2/46.5	1219.6/48.0	1260.0/49.6	1301.1/51.2
<b>D</b>	945.4/37.2	986.5/38.8	1025.5/40.4	1065.8/42.0	1106.8/43.6	1145.2/45.1	1185.6/46.7	1226.7/48.3
<b>E</b>	1009.4/39.7	1050.5/41.4	1089.5/42.9	1129.8/44.5	1170.8/46.1	1209.2/47.6	1249.6/49.2	1290.7/50.8

	1240mm	1280mm	1320mm	1360mm	1400mm	1440mm	1480mm	1520mm
<b>A</b>	1242.1/48.9	1281.8/50.5	1323.6/52.1	1362.0/53.6	1401.7/55.2	1443.4/56.8	1481.8/58.3	1521.5/59.9
<b>B</b>	1378.1/54.3	1417.8/55.8	1459.6/57.5	1498.0/59.0	1537.7/60.5	1579.4/62.2	1617.8/63.7	1657.5/65.3
<b>C</b>	1339.4/52.7	1379.1/54.3	1420.9/55.9	1459.3/57.5	1499.0/59.0	1540.7/60.7	1579.1/62.2	1618.8/63.7
<b>D</b>	1265.0/49.8	1304.7/51.4	1346.5/53.0	1384.9/54.5	1424.6/56.1	1466.3/57.7	1504.7/59.2	1544.4/60.1
<b>E</b>	1329.0/52.3	1368.7/53.9	1410.5/55.5	1448.9/57.0	1488.6/58.6	1530.3/60.2	1568.7/61.8	1608.4/63.3

	1560mm	1600mm	1640mm	1680mm	1720mm	1760mm	1800mm	1840mm
<b>A</b>	1563.3/61.6	1600.9/63.0	1641.3/64.6	1683.1/66.3	1720.8/67.8	1760.5/69.3	1802.9/71.0	1840.6/72.5
<b>B</b>	1699.3/66.9	1736.9/68.4	1777.3/70.0	1819.1/71.6	1856.8/73.1	1896.5/74.7	1938.9/76.3	1976.6/77.8
<b>C</b>	1660.6/65.4	1698.2/66.9	1738.6/68.5	1780.4/70.0	1818.8/71.6	1857.8/73.1	1900.2/74.8	1937.9/76.3
<b>D</b>	1586.2/62.5	1623.8/63.9	1664.2/65.5	1706.0/67.2	1743.7/68.7	1783.4/70.2	1825.8/71.9	1863.5/73.4
<b>E</b>	1650.2/65.0	1687.8/66.5	1728.2/68.0	1770.0/69.7	1807.7/71.2	1847.4/72.7	1889.8/74.4	1927.5/75.9

	1880mm	1920mm	1960mm	2000mm	2040mm	2080mm	2120mm
<b>A</b>	1880.3/74.0	1922.8/75.7	1960.4/77.2	2000.1/78.7	2042.6/80.4	2079.6/81.8	2120.0/83.5
<b>B</b>	2016.3/79.4	2058.8/81.1	2096.4/82.5	2136.1/84.1	2178.6/85.8	2215.6/87.2	2256.0/88.8
<b>C</b>	1977.6/77.9	2020.1/79.5	2057.7/81.0	2097.4/82.6	2139.9/84.3	2176.9/85.7	2217.3/87.3
<b>D</b>	1903.2/74.9	1945.7/76.6	1983.3/78.1	2023.0/79.7	2065.5/81.3	2102.9/82.8	2142.9/84.4
<b>E</b>	1967.2/77.5	2009.7/79.1	2047.3/80.6	2087.0/82.2	2129.5/83.8	2166.5/85.3	2206.9/86.9

**Table 13-6 MS4800-40 Transmitter and Receiver Dimensions**

	360mm	480mm	600mm	720mm	840mm	960mm	1080mm	1200mm
<b>A</b>	364.5/14.4	484.3/19.1	604.1/23.8	724.0/28.5	843.4/31.6	963.6/37.9	1083.9/42.7	1203.8/47.4
<b>B</b>	500.5/19.7	620.3/24.4	740.1/29.1	860.0/33.9	979.8/38.6	1099.6/43.3	1219.9/48.0	1339.8/52.7
<b>C</b>	461.8/18.2	581.6/22.9	701.4/27.6	821.3/32.3	941.1/37.1	1060.9/41.8	1181.2/46.5	1301.1/51.2
<b>D</b>	387.4/15.3	507.2/19.9	627.0/24.7	746.9/29.4	866.7/34.1	986.5/38.8	1106.8/43.6	1226.7/48.3
<b>E</b>	451.4/17.8	571.2/22.5	691.0/27.2	810.9/31.9	930.7/36.6	1050.5/41.4	1170.8/46.1	1290.7/50.8

	1320mm	1440mm	1560mm	1680mm	1800mm	1920mm	2040mm
<b>A</b>	1323.6/52.1	1443.4/56.8	1563.3/61.6	1683.1/66.3	1802.9/71.0	1922.8/75.7	2042.6/80.4
<b>B</b>	1459.6/57.5	1579.4/62.2	1699.3/66.9	1819.1/71.6	1938.9/76.3	2058.8/81.1	2178.6/85.8
<b>C</b>	1420.9/55.9	1540.7/60.7	1660.6/65.4	1780.4/70.0	1900.2/74.8	2020.1/79.5	2139.9/84.3
<b>D</b>	1346.5/53.0	1466.3/57.7	1586.2/62.5	1706.0/67.2	1825.8/71.9	1945.7/76.6	2065.5/81.3
<b>E</b>	1410.5/55.5	1530.3/60.2	1650.2/65.0	1770.0/69.7	1889.8/74.4	2009.7/79.1	2129.5/83.8

**13.4 MINISAFE CASCADED MSF4800 DIMENSION DRAWINGS**

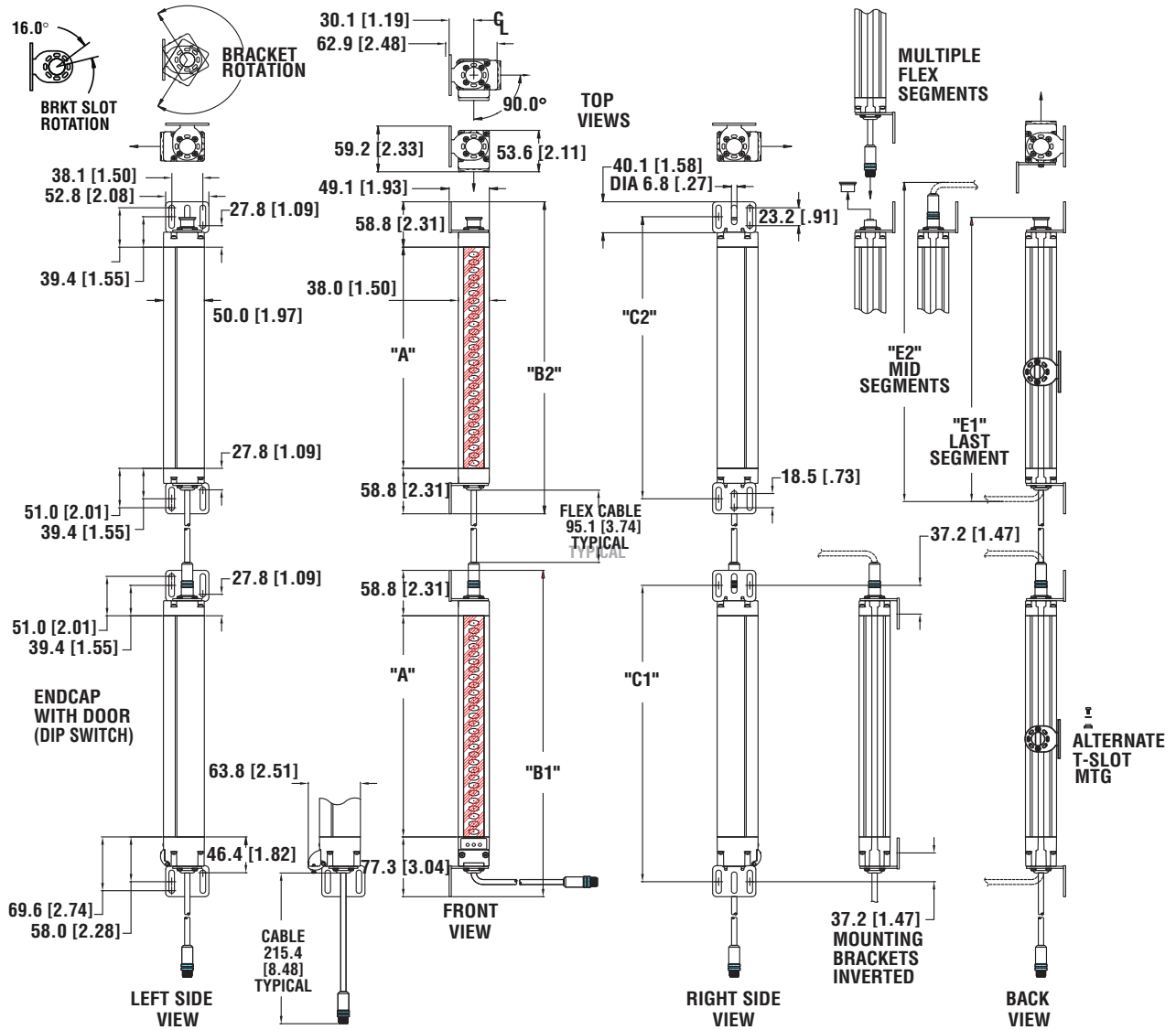

Figure 13-2 MSF4800 Dimension Drawings

Table 13-7 MSF4800-14/20 Transmitter and Receiver Dimensions

	240mm	280mm	320mm	360mm	400mm	440mm	480mm	520mm
<b>A</b>	244.6/9.6	284.4/11.2	324.8/12.8	364.5/14.4	404.2/15.9	443.9/17.5	484.3/19.1	523.4/20.6
<b>B1</b>	380.6/15.0	420.4/16.6	460.8/18.1	500.5/19.7	540.2/21.3	579.9/22.8	620.3/24.4	659.4/26.0
<b>B2</b>	362.1/14.3	401.9/15.8	442.3/17.4	482.0/19.0	521.7/20.5	561.4/22.1	601.8/23.7	640.9/25.2
<b>C1</b>	341.9/13.5	381.7/15.0	422.1/16.6	461.8/18.2	501.5/19.7	541.2/21.3	581.6/22.9	620.7/24.4
<b>C2</b>	323.3/12.7	363.1/14.3	403.5/15.9	443.2/17.5	482.9/19.0	522.6/20.6	563.0/22.2	602.1/23.7
<b>D</b>	400.2/15.8	440.0/17.3	480.4/18.9	520.1/20.5	559.8/22.0	599.5/23.6	639.9/25.2	679.0/26.7
<b>E1</b>	327.9/12.9	367.7/14.5	408.1/16.1	447.8/17.6	487.5/19.2	527.2/20.8	567.6/22.4	606.7/23.9
<b>E2</b>	381.6/15.0	421.4/16.6	461.8/18.2	501.5/19.7	541.2/21.3	580.9/22.9	621.3/24.5	660.4/26.0

	560mm	600mm	640mm	680mm	720mm	760mm	800mm	840mm
<b>A</b>	563.7/22.2	604.1/23.8	643.9/25.4	683.6/26.9	724.0/28.5	763.0/30.0	803.5/31.6	843.8/33.2
<b>B1</b>	699.7/27.6	740.1/29.1	779.9/30.7	819.6/32.3	860.0/33.9	898.0/35.4	939.5/37.0	979.8/38.6
<b>B2</b>	681.2/26.8	721.6/28.4	761.4/30.0	801.1/31.5	841.5/33.1	880.5/34.7	921.0/36.3	961.3/37.9
<b>C1</b>	661.0/26.0	701.4/27.6	741.2/29.2	780.9/30.7	821.3/32.3	860.3/33.9	900.8/35.5	941.1/37.1
<b>C2</b>	642.4/25.3	682.8/26.9	722.6/28.4	762.3/30.0	802.7/31.6	841.7/33.1	882.2/34.7	922.5/36.3
<b>D</b>	719.3/28.3	759.7/30.0	799.5/31.5	839.2/33.0	879.6/34.6	918.6/36.2	959.1/37.8	999.4/39.4
<b>E1</b>	647.0/25.5	687.4/27.1	727.2/28.6	766.9/30.2	807.3/31.8	846.3/33.3	886.8/34.9	927.1/36.5
<b>E2</b>	700.7/27.6	741.1/29.2	780.9/30.7	820.6/32.3	861.0/33.9	900.0/35.4	940.5/37.0	980.8/38.6

	880mm	920mm	960mm	1000mm	1040mm	1080mm	1120mm	1160mm
<b>A</b>	882.8/34.8	922.5/36.32	963.6/37.9	1002.6/39.5	1042.9/41.1	1083.9/42.7	1122.3/44.2	1162.7/45.8
<b>B1</b>	1018.8/40.1	1058.5/41.7	1099.6/43.3	1138.6/44.8	1178.9/46.4	1219.9/48.0	1258.3/49.5	1298.7/51.1
<b>B2</b>	1000.3/39.4	1040.0/41.0	1081.1/42.7	1120.1/44.1	1160.4/45.7	1201.4/47.3	1239.8/48.8	1280.2/50.4
<b>C1</b>	980.1/38.6	1019.8/40.2	1060.9/41.8	1099.9/43.3	1140.2/44.9	1181.2/46.5	1219.6/48.0	1260.0/49.6
<b>C2</b>	961.5/37.9	1001.2/39.5	1042.3/41.0	1081.3/42.6	1121.6/44.2	1162.6/45.8	1201.0/47.3	1241.4/48.9
<b>D</b>	1038/40.9	1078.1/42.5	1119.2/44.1	1158.2/45.6	1198.5/47.2	1239.5/48.8	1277.9/50.3	1318.3/51.9
<b>E1</b>	966.1/38.0	1005.8/39.6	1046.9/41.2	1085.9/42.8	1126.2/44.3	1167.2/46.0	1205.6/47.5	1246.0/49.1
<b>E2</b>	1019.8/40.2	1059.9/41.7	1100.6/43.3	1139.6/44.8	1179.9/46.5	1220.9/48.1	1259.3/49.6	1299.7/51.2

	1200mm	1240mm	1280mm	1320mm	1360mm*	1400mm*	1440mm*	1480mm*
<b>A</b>	1203.8/47.4	1242.1/48.9	1281.8/50.5	1323.6/52.1	1362.0/53.6	1401.7/55.2	1443.4/56.8	1481.8/58.3
<b>B1</b>	1339.8/52.8	1378.1/54.3	1417.8/55.8	1459.6/57.5	1498.0/59.0	1537.7/60.5	1579.4/62.2	1617.8/63.7
<b>B2</b>	1321.3/52.0	1359.6/53.5	1399.3/55.1	1441.1/56.7	1479.5/58.3	1519.2/59.8	1560.9/61.5	1599.3/63.0
<b>C1</b>	1301.1/51.2	1339.4/52.7	1379.1/54.3	1420.9/55.9	1459.3/57.5	1499.0/59.0	1540.7/60.7	1579.1/62.2
<b>C2</b>	1282.5/50.5	1320.8/52.0	1360.5/53.6	1402.3/55.2	1440.7/56.7	1480.4/58.3	1522.1/59.9	1560.5/61.4
<b>D</b>	1359.4/53.5	1397.7/55.0	1437.4/56.6	1479.2/58.2	1517.6/59.8	1557.3/61.3	1599.0/63.0	1637.4/64.5
<b>E1</b>	1287.1/50.8	1325.4/52.2	1365.1/53.8	1406.9/55.4	1445.3/56.9	1485.0/58.5	1526.7/60.1	1565.1/61.6
<b>E2</b>	1340.8/52.8	1379.1/54.3	1418.8/55.9	1460.6/57.5	1499.0/59.0	1538.7/60.6	1580.4/62.2	1618.8/63.7

	1520mm*	1560mm*	1600mm*	1640mm*	1680mm*	1720mm*	1760mm*	1800mm*
<b>A</b>	1521.5/59.9	1563.3/61.6	1600.9/63.0	1641.3/64.6	1683.1/66.3	1720.8/67.8	1760.5/69.3	1802.9/71.0
<b>B1</b>	1657.5/65.3	1699.3/66.9	1736.9/68.4	1777.3/70.0	1819.1/71.6	1856.8/73.1	1896.5/74.7	1938.9/76.3
<b>B2</b>	1639.0/64.5	1680.8/66.2	1718.4/67.7	1758.8/69.2	1800.6/70.9	1838.3/72.4	1878.0/73.9	1920.4/75.6
<b>C1</b>	1618.8/63.7	1660.6/65.4	1698.2/66.9	1738.6/68.5	1780.4/70.1	1818.1/71.6	1857.8/73.1	1900.2/74.8
<b>C2</b>	1600.2/63.0	1642.0/64.6	1679.6/66.1	1720.0/67.7	1761.8/69.4	1799.5/70.8	1839.2/72.4	1881.6/74.1
<b>D</b>	1677.1/66.0	1718.9/67.7	1756.5/69.2	1796.9/70.7	1838.7/72.4	1876.4/73.9	1916.1/75.4	1958.5/77.1
<b>E1</b>	1604.8/63.2	1646.6/64.8	1684.2/66.3	1724.6/67.9	1766.4/69.5	1804.1/71.0	1843.8/72.6	1886.2/74.3
<b>E2</b>	1658.5/65.3	1700.3/66.9	1737.9/68.4	1778.3/70.0	1820.1/71.7	1857.8/73.1	1897.5/74.7	1939.9/76.4

\*Not available as a mid-segment.

**Table 13-8 MSF4800-30 Transmitter and Receiver Dimensions**

	240mm	280mm	320mm	360mm	400mm	440mm	480mm	520mm
<b>A</b>	244.6/9.6	284.4/11.2	324.8/12.8	364.5/14.4	404.2/15.9	443.9/17.5	484.3/19.1	523.4/20.6
<b>B1</b>	380.6/15.0	420.4/16.6	460.8/18.1	500.5/19.7	540.2/21.3	579.9/22.8	620.3/24.4	659.4/26.0
<b>B2</b>	362.1/14.3	401.9/15.8	442.3/17.4	482.0/19.0	521.7/20.5	561.4/22.1	601.8/23.7	640.9/25.2
<b>C1</b>	341.9/13.5	381.7/15.0	422.1/16.6	461.8/18.2	501.5/19.7	541.2/21.3	581.6/22.9	620.7/24.4
<b>C2</b>	323.3/12.7	363.1/14.3	403.5/15.9	443.2/17.5	482.9/19.0	522.6/20.6	563.0/22.2	602.1/23.7
<b>D</b>	400.2/15.8	440.0/17.3	480.4/18.9	520.1/20.5	559.8/22.0	599.5/23.6	639.9/25.2	679.0/26.7
<b>E1</b>	327.9/12.9	367.7/14.5	408.1/16.1	447.8/17.6	487.5/19.2	527.2/20.8	567.6/22.4	606.7/23.9
<b>E2</b>	381.6/15.0	421.4/16.6	461.8/18.2	501.5/19.7	541.2/21.3	580.9/22.9	621.3/24.5	660.4/26.0

	560mm	600mm	640mm	680mm	720mm	760mm	800mm	840mm
<b>A</b>	563.7/22.2	604.1/23.8	643.9/25.4	683.6/26.9	724.0/28.5	763.0/30.0	803.5/31.6	843.8/33.2
<b>B1</b>	699.7/27.6	740.1/29.1	779.9/30.7	819.6/32.3	860.0/33.9	898.0/35.4	939.5/37.0	979.8/38.6
<b>B2</b>	681.2/26.8	721.6/28.4	761.4/30.0	801.1/31.5	841.5/33.1	880.5/34.7	921.0/36.3	961.3/37.9
<b>C1</b>	661.0/26.0	701.4/27.6	741.2/29.2	780.9/30.7	821.3/32.3	860.3/33.9	900.8/35.5	941.1/37.1
<b>C2</b>	642.4/25.3	682.8/26.9	722.6/28.4	762.3/30.0	802.7/31.6	841.7/33.1	882.2/34.7	922.5/36.3
<b>D</b>	719.3/28.3	759.7/30.0	799.5/31.5	839.2/33.0	879.6/34.6	918.6/36.2	959.1/37.8	999.4/39.4
<b>E1</b>	647.0/25.5	687.4/27.1	727.2/28.6	766.9/30.2	807.3/31.8	846.3/33.3	886.8/34.9	927.1/36.5
<b>E2</b>	700.7/27.6	741.1/29.2	780.9/30.7	820.6/32.3	861.0/33.9	900.0/35.4	940.5/37.0	980.8/38.6

	880mm	920mm	960mm	1000mm	1040mm	1080mm	1120mm	1160mm
<b>A</b>	882.8/34.8	922.5/36.3	963.6/37.9	1002.6/39.5	1042.9/41.1	1083.9/42.7	1122.3/44.2	1162.7/45.8
<b>B1</b>	1018.8/40.1	1058.5/41.7	1099.6/43.3	1138.6/44.8	1178.9/46.4	1219.9/48.0	1258.3/49.5	1298.7/51.1
<b>B2</b>	1000.3/39.4	1040.0/41.0	1081.1/42.7	1120.1/44.1	1160.4/45.7	1201.4/47.3	1239.8/48.8	1280.2/50.4
<b>C1</b>	980.1/38.6	1019.8/40.2	1060.9/41.8	1099.9/43.3	1140.2/44.9	1181.2/46.5	1219.6/48.0	1260.0/49.6
<b>C2</b>	961.5/37.9	1001.2/39.5	1042.3/41.0	1081.3/42.6	1121.6/44.2	1162.6/45.8	1201.0/47.3	1241.4/48.9
<b>D</b>	1038/40.9	1078.1/42.5	1119.2/44.1	1158.2/45.6	1198.5/47.2	1239.5/48.8	1277.9/50.3	1318.3/51.9
<b>E1</b>	966.1/38.0	1005.8/39.6	1046.9/41.2	1085.9/42.8	1126.2/44.3	1167.2/46.0	1205.6/47.5	1246.0/49.1
<b>E2</b>	1019.8/40.2	1059.9/41.7	1100.6/43.3	1139.6/44.8	1179.9/46.5	1220.9/48.1	1259.3/49.6	1299.7/51.2

	1200mm	1240mm	1280mm	1320mm	1360mm*	1400mm*	1440mm*	1480mm*
A	1203.8/47.4	1242.1/48.9	1281.8/50.5	1323.6/52.1	1362.0/53.6	1401.7/55.2	1443.4/56.8	1481.8/58.3
B1	1339.8/52.8	1378.1/54.3	1417.8/55.8	1459.6/57.5	1498.0/59.0	1537.7/60.5	1579.4/62.2	1617.8/63.7
B2	1321.3/52.0	1359.6/53.5	1399.3/55.1	1441.1/56.7	1479.5/58.3	1519.2/59.8	1560.9/61.5	1599.3/63.0
C1	1301.1/51.2	1339.4/52.7	1379.1/54.3	1420.9/55.9	1459.3/57.5	1499.0/59.0	1540.7/60.7	1579.1/62.2
C2	1282.5/50.5	1320.8/52.0	1360.5/53.6	1402.3/55.2	1440.7/56.7	1480.4/58.3	1522.1/59.9	1560.5/61.4
D	1359.4/53.5	1397.7/55.0	1437.4/56.6	1479.2/58.2	1517.6/59.8	1557.3/61.3	1599.0/63.0	1637.4/64.5
E1	1287.1/50.8	1325.4/52.2	1365.1/53.8	1406.9/55.4	1445.3/56.9	1485.0/58.5	1526.7/60.1	1565.1/61.6
E2	1340.8/52.8	1379.1/54.3	1418.8/55.9	1460.6/57.5	1499.0/59.0	1538.7/60.6	1580.4/62.2	1618.8/63.7
	1520mm*	1560mm*	1600mm*	1640mm*	1680mm*	1720mm*	1760mm*	1800mm*
A	1521.5/59.9	1563.3/61.6	1600.9/63.0	1641.3/64.6	1683.1/66.3	1720.8/67.8	1760.5/69.3	1802.9/71.0
B1	1657.5/65.3	1699.3/66.9	1736.9/68.4	1777.3/70.0	1819.1/71.6	1856.8/73.1	1896.5/74.7	1938.9/76.3
B2	1639.0/64.5	1680.8/66.2	1718.4/67.7	1758.8/69.2	1800.6/70.9	1838.3/72.4	1878.0/73.9	1920.4/75.6
C1	1618.8/63.7	1660.6/65.4	1698.2/66.9	1738.6/68.5	1780.4/70.1	1818.1/71.6	1857.8/73.1	1900.2/74.8
C2	1600.2/63.0	1642.0/64.6	1679.6/66.1	1720.0/67.7	1761.8/69.4	1799.5/70.8	1839.2/72.4	1881.6/74.1
D	1677.1/66.0	1718.9/67.7	1756.5/69.2	1796.9/70.7	1838.7/72.4	1876.4/73.9	1916.1/75.4	1958.5/77.1
E1	1604.8/63.2	1646.6/64.8	1684.2/66.3	1724.6/67.9	1766.4/69.5	1804.1/71.0	1843.8/72.6	1886.2/74.3
E2	1658.5/65.3	1700.3/66.9	1737.9/68.4	1778.3/70.0	1820.1/71.7	1857.8/73.1	1897.5/74.7	1939.9/76.4
	1840mm	1880mm	1920mm	1960mm	2000mm	2040mm	2080mm	2120mm
A	1840.6/72.5	1880.3/74.0	1922.8/75.7	1960.4/77.2	2000.1/78.7	2042.6/80.4	2079.6/81.9	2120.0/83.5
B1	1976.6/77.8	2016.3/79.4	2058.8/81.1	2096.4/82.5	2136.1/84.1	2178.6/85.8	2215.6/87.2	2256.7/88.8
B2	1958.1/77.1	1997.8/78.7	2040.3/80.3	2077.9/81.8	2117.6/83.4	2160.1/85.0	2197.1/86.5	2237.5/88.1
C1	1937.9/76.3	1977.6/77.9	2020.1/79.5	2057.7/81.0	2097.4/82.6	2139.9/84.3	2176.9/85.7	2217.3/87.3
C2	1919.3/75.6	1959.0/77.1	2001.5/78.8	2039.1/80.3	2078.8/81.8	2121.3/83.5	2158.3/85.0	2198.7/86.6
D	1996.2/78.6	2035.9/80.2	2078.4/81.8	2116.0/83.3	2155.7/84.9	2198.2/86.5	2235.2/88.0	2275.6/89.6
E1	1923.9/75.7	1963.6/77.3	2006.1/79.0	2043.7/80.5	2083.4/82.0	2125.9/83.7	2162.9/85.2	2203.3/86.7
E2	1977.6/77.9	2017.3/79.4	2059.8/81.1	2097.4/82.6	2137.1/84.1	2179.6/85.8	2216.6/87.3	2257.0/88.9

Table 13-9 MSF4800-40 Transmitter and Receiver Dimensions

	360mm	480mm	600mm	720mm	840mm	960mm	1080mm	1200mm
A	364.5/14.4	484.3/19.1	604.1/23.8	724.0/28.5	843.8/33.2	963.6/37.9	1083.9/42.7	1203.8/47.4
B1	500.5/19.7	620.3/24.4	740.1/29.1	860.0/33.9	979.8/38.6	1099.6/43.3	1219.9/48.0	1339.8/52.8
B2	482.0/19.0	601.8/23.7	721.6/28.4	841.5/33.1	961.3/37.9	1081.1/42.7	1201.4/47.3	1321.3/52.0
C1	461.8/18.2	581.6/22.9	701.4/27.6	821.3/32.3	941.1/37.1	1060.9/41.8	1181.2/46.5	1301.1/51.2
C2	443.2/17.5	563.0/22.2	682.8/26.9	802.7/31.6	922.5/36.3	1042.3/41.0	1162.6/45.8	1282.5/50.5
D	520.1/20.5	639.9/25.2	759.7/30.0	879.6/34.6	999.4/39.4	1119.2/44.1	1239.5/48.8	1359.4/53.5
E1	447.8/17.6	567.6/22.4	687.4/27.1	807.3/31.8	927.1/36.5	1046.9/41.2	1167.2/46.0	1287.1/50.8
E2	501.5/19.7	621.3/24.5	741.1/29.2	861.0/33.9	980.8/38.6	1100.6/43.3	1220.9/48.1	1340.8/52.8

	1320mm	1440mm*	1560mm*	1680mm*	1800mm*	1920mm	2040mm
<b>A</b>	1323.6/52.1	1443.4/56.8	1563.3/61.6	1683.1/66.3	1802.9/71.0	1922.8/75.7	2042.6/80.4
<b>B1</b>	1459.6/57.5	1579.4/62.2	1699.3/66.9	1819.1/71.6	1938.9/76.3	2058.8/81.1	2178.6/85.8
<b>B2</b>	1441.1/56.7	1560.9/61.5	1680.8/66.2	1800.6/70.9	1920.4/75.6	2040.3/80.3	2160.1/85.0
<b>C1</b>	1420.9/55.9	1540.7/60.7	1660.6/65.4	1780.4/70.1	1900.2/74.8	2020.1/79.5	2139.9/84.3
<b>C2</b>	1402.3/55.2	1522.1/59.9	1642.0/64.6	1761.8/69.4	1881.6/74.1	2001.5/78.8	2121.3/83.5
<b>D</b>	1479.2/58.2	1599.0/63.0	1718.9/67.7	1838.7/72.4	1958.5/77.1	2078.4/81.8	2198.2/86.5
<b>E1</b>	1406.9/55.4	1526.7/60.1	1646.6/64.8	1766.4/69.5	1886.2/74.3	2006.1/79.0	2125.9/83.7
<b>E2</b>	1460.6/57.5	1580.4/62.2	1700.3/66.9	1820.1/71.7	1939.9/76.4	2059.8/81.1	2179.6/85.8

### 13.5 WARRANTY

Omron STI warrants its products to be free from defects of material and workmanship and will, without charge, replace or repair any equipment found defective upon inspection at its factory, provided the equipment has been returned, transportation prepaid, within one year from the date of installation and not to exceed 18 months from date of factory shipment.

The foregoing warranty is in lieu of and excludes all other warranties not expressly set forth herein, whether expressed or implied by operation of law or otherwise including but not limited to any implied warranties of merchantability or fitness for a particular purpose. No representation or warranty, express or implied, made by any sales representative, distributor, or other agent or representative of Omron STI which is not specifically set forth herein shall be binding upon Omron STI. Omron STI shall not be liable for any incidental or consequential damages, losses or expenses directly or indirectly arising from the sale, handling, improper application or use of the goods or from any other cause relating thereto and Omron STI's liability hereunder, in any case, is expressly limited to repair or replacement (at Omron STI's option) of goods.

Warranty is specifically at the factory or an Omron STI authorized service location. Any on site service will be provided at the sole expense of the Purchaser at standard field service rates.

All associated equipment must be protected by properly rated electronic/electrical protection devices. Omron STI shall not be liable for any damage due to improper engineering or installation by the purchaser or third parties. Proper installation, operation and maintenance of the product becomes the responsibility of the user upon receipt of the product.

### 13.6 PATENTS

Elements of the electronics and optics essential to meet the specifications and performance standards of Omron STI controls are covered by one or more of the following U.S. Patent Numbers: 3,774,039; 3,867,628; 3,967,111; 3,996,476; 4,007,387; 4,101,784; 5,015,840; Design 255,031, and other patents pending.

### 13.7 TRADEMARKS

MiniSafe™, is a trademark of Omron Scientific Technologies, Inc.

### 13.8 REPAIRS

Omron STI offers product repair service at our factory. If you need repairs made to any Omron STI product contact our Customer Service Department.

### **13.9 DOCUMENTATION CRITERIA**

This publication has been carefully checked for accuracy and is believed to be fully consistent with the products it describes. However, Omron STI does not assume liability for the contents of this publication, the examples used within, or the use of any product described herein. Omron STI reserves the right to make changes to products and/or documentation without further notification.

### **13.10 COMPLIANCE WITH ROHS**

The MS4800 product was developed in compliance with the 'restriction of the use of certain hazardous substances' (RoHS).

## 14 GLOSSARY

### 14.1 GLOSSARY DEFINITIONS

**Automatic Start:** Upon completion of power-up, the ESPE will enter the MACHINE RUN state as soon as the detection zone is clear of opaque objects of the specified size.

**Detection Zone:** The IR light sensing area of the ESPE. When a specified test piece enters this area then the ESPE must detect its presence and set its safety outputs to the OFF-state.

**Electro-Sensitive Protective Equipment (ESPE):** An assembly of devices and/or components working together for protective tripping or presence sensing purposes and comprising as a minimum:

- a sensing device
- controlling/monitoring devices
- output signal switching devices

**LOCKOUT Condition:** When the ESPE detects a fault, it transitions to this state. The OSSD will be held to the OFF state and the ESPE will not attempt to leave this state without performing a comprehensive power-up self-test. A power-up self-test will be initiated by either cycling the ESPE power or by a Start signal transition.

**MACHINE RUN:** When the ESPE is in this state the two OSSD are both active. In this state the Green MACHINE RUN LED is on, the Red MACHINE STOP LED is off and the Yellow INTERLOCK LED is off.

**MACHINE STOP:** When the ESPE is in this state the two OSSD are both inactive. In this state the Green MACHINE RUN LED is off, the Red MACHINE STOP LED is on.

**OFF-State:** The state in which the output circuit is interrupted and does not permit the flow of current.

**ON-State:** The state in which the output circuit is completed and permits the flow of current.

**Output Signal Switching Device (OSSD):** The safety output of the ESPE that is used to enable and disable the guarded machine.

**Response Time:** The maximum amount of time required for the ESPE to set its OSSD outputs to the OFF-state once the detection zone is blocked by an opaque object of the specified size.

**Start INTERLOCK:** Upon completion of power-up, the ESPE must go to the “INTERLOCK” state. A Start signal transition must occur before going to MACHINE RUN for the first time. Once the first Start condition has been met, the ESPE will operate in the Automatic Start mode.

**Start/Restart INTERLOCK:** The ESPE will go into the INTERLOCK state upon completion of power-up and during zone violations which causes a transition to the MACHINE STOP state. A Start signal transition must occur before returning to MACHINE RUN following any transition to MACHINE STOP.

## 15 DIAGNOSTICS & TROUBLESHOOTING

### 15.1 DIAGNOSTICS

The diagnostic fault codes are given in the following table. These codes are displayed via the IBIs.

**Table 15-1 Diagnostic Codes**

Code Group	Error Code	Description of Error Code	Corrective Action Needed
Configuration Switch Faults (MS4800S only)	21	Invalid mode selection setting	Verify switch setting. See user manual.
	22	Configuration switch settings changed during operation	Verify switch setting. See user manual.
	23	Configuration switch settings do not match	Verify switch setting. See user manual.
	24	Corrupted EEPROM configuration.	Reset the system configuration to factory default.
	26	Invalid scan code setting	Verify switch setting. See user manual.
Safety Output (OSSD) Faults	31	Safety outputs 1 & 2 are shorted together	Check and correct wiring of safety outputs 1 and 2.
	32	Safety output 1 shorted to power	Check and correct wiring of safety output 1.
	33	Safety output 2 shorted to power	Check and correct wiring of safety output 2.
	34	Safety output 1 shorted to ground	Check and correct wiring of safety output 1.
	35	Safety output 2 shorted to ground	Check and correct wiring of safety output 2.
EDM Faults	41	EDM circuit did not open before transition to MACHINE RUN State	Check and correct EDM wiring.
	42	EDM circuit did not open after transition to MACHINE RUN state	Check and correct EDM wiring.
	43	EDM circuit was in wrong state during power-up	Check and correct EDM wiring.
	44	EDM fault at power-up	Check start input wire or EDM function selection.
Controller Fault	50	Control logic fault	Call Omron STI(888-510-4357) or return receiver to Omron STI for evaluation
Setup Error	60	Possible crosstalk	Possible crosstalk
Muting Faults	70	General muting fault	Check wiring of unused mute sensors.
	71	Mute sensors activated in the wrong sequence	Check mounting of mute sensors for correct sequence.
	74	Mute lamp burned out or not connected	Check status of mute lamp.
Cascaded System Faults	80	Configuration error	Call Omron STI for troubleshooting assistance (888-510-4357)
	81	Second segment or mute module error	Check all cable connections. Call Omron STI (888-510-4357)
	82	Third segment or mute module error	Check all cable connections. Call Omron STI (888-510-4357)
	83	Fourth segment or mute module error	Check all cable connections. Call Omron STI (888-510-4357)
	84	Mute module error	Check all cable connections to mute module. Call Omron STI (888-510-4357)

Code Group	Error Code	Description of Error Code	Corrective Action Needed
	85	Configuration error	Call Omron STI for troubleshooting assistance (888-510-4357)
	86	Second segment or mute module firmware not compatible with first segment	Replace with compatible component or return system to Omron STI for upgrade.
	87	Third segment or mute module firmware not compatible with first segment	Replace with compatible component or return system to Omron STI for upgrade.
	88	Fourth segment or mute module firmware not compatible with first segment	Replace with compatible component or return system to Omron STI for upgrade.
	89	Mute module firmware not compatible with first segment	Replace with compatible component or return system to Omron STI for upgrade.
	90	Incorrect segment type in position two, three, or four	Confirm that all segments are of the same type; either all transmitters or all receivers.
	91	Segment 2 type does not match segment 1 type	Confirm that segment 2 is the same type (transmitter or receiver) as segment 1.
	92	Segment 3 type does not match segment 1 type	Confirm that segment 3 is the same type (transmitter or receiver) as segment 1.
	93	Segment 4 type does not match segment 1 type	Confirm that segment 4 is the same type (transmitter or receiver) as segment 1.
	95	Error in flex segment or mute during operation	Check connections. Call Omron STI (888-510-4357)
	96	Error in segment 2 during operation	Check connections to segment 2. Replace segment 2 with known good segment. Call Omron STI (888-510-4357).
	97	Error in segment 3 during operation	Check connections to segment 3. Replace segment 3 with known good segment. Call Omron STI (888-510-4357).
	98	Error in segment 4 during operation	Check connections to segment 4. Replace segment 4 with known good segment. Call Omron STI (888-510-4357).
	100	Number of segments in system has been reduced	Segment count is less than original configuration. Add required segment(s) or program system for current configuration.
	101	Too many flex nodes or mute modules in the flexbus	Make sure of total of 4 segments with only one mute module.

## 15.2 RECEIVER DIAGNOSTIC INFORMATION

The receiver first segment uses the IBI to indicate diagnostic codes. The IBI will only indicate fault codes, when in the Fault state. In this state the yellow INTERLOCK LED will be flashing and the first 10 IBIs are used to display the fault code, see Figure 15-1 *Example of IBI LED's used to Show Fault Code*.

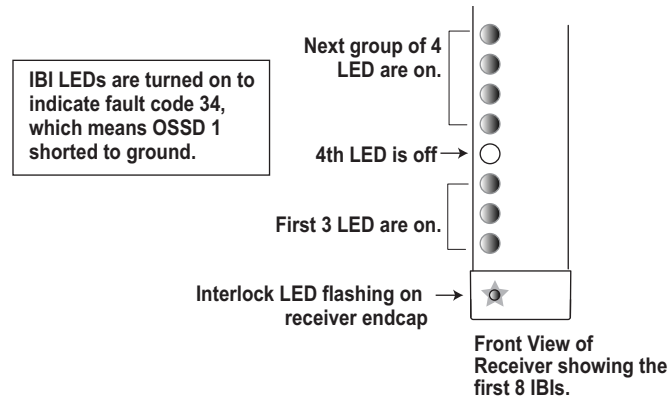

Figure 15-1 Example of IBI LED's used to Show Fault Code

## 15.3 RECEIVER ENDCAP INDICATOR LIGHTS

1. GREEN – The MS4800 is in the MACHINE RUN state.
2. RED - The MS4800 is in the MACHINE STOP state.
3. YELLOW INTERLOCK- The light curtain is waiting for the start button to be pushed. If the LED is blinking, the light curtain is in a alarm condition.
4. AMBER – The light curtain is operating in a reduced resolution mode: Floating Blanking, Fixed Blanking, Monitored Blanking and Reduced Resolution.

### 15.3.1 RECEIVER TROUBLESHOOTING

If the yellow INTERLOCK LED is blinking:

1. Check the configuration for MPCE Monitoring. If MPCE Monitoring is inactive (via receiver selector switches), the input (pink wire) must be connected to system ground. If MPCE is active, the input must be connected to the normally closed contacts of the control relays of the guarded machine or the monitor terminal of the RM module. See Section 10 -- *Connecting To The Machine Control Circuit* for an example.
2. Make sure both selector switches in the receiver endcap have been set properly and identically. See Table 6-2 *Receiver Selector Switch Settings* in manual.
3. Verify the power supply is within specified limits, see Section 13.1 -- *System Specifications*.
4. Verify the light curtain is properly connected to the control relays of the guarded machine. If the light curtain is not intended to be connected to control relays, see Section 10.1 -- *Connecting to a Safety Monitoring Device* of the manual for instruction.
5. Verify the control relays are within operating limits of the safety outputs. See Section 13 -- *Specifications and Additional Information*.

Note: The pull-in voltage requirement of the relays must be satisfied. The 4800 provides  $V = V_{\text{supply}} - 2V$  on each solid-state safety output.

6. Verify the cable lengths from the light curtain to the control relays are within specified limits. See Section 13.1 -- *System Specifications*.
7. Call Omron STI's Application Engineering Department at 1/888/510-4357.

#### **15.4 TROUBLESHOOTING THE TRANSMITTER**

If the yellow LED is off:

1. Verify the cable is connected.
2. Verify the power supply is within limits (+24V  $\pm$  20%).
3. Call Omron STI's Application Engineering Department at 1/888/510-4357.

If the yellow LED is blinking:

1. Verify the power supply is within limits (+24V  $\pm$  20%).
2. Call Omron STI's Application Engineering Department at 1/888/510-4357.

# APPENDIX A —CHECKOUT PROCEDURE

## A.1 CHECKOUT PROCEDURE LOG

The following checkout procedure must be performed by qualified personnel during initial MS4800 system installation and at least every three months or more frequently depending on machine usage and company guidelines.

Machine Identification: \_\_\_\_\_ Date: \_\_\_\_\_

Item	Condition	Comments
1. Verify that the guarded machine is compatible with the type of machine which maybe used with the MS4800 system. See Section 1 -- <i>Important Safety Warnings</i> for further information.	___ Pass ___ Fail	
2. Verify that the mounting distance of the MS4800 system is equal to or greater than the minimum safe distance from the danger point. See Section 8 -- <i>Safe Mounting Distance</i> for further information.	___ Pass ___ Fail	
3. Determine that all access to the danger point not protected by the MS4800 system is guarded by other means, such as gates, fencing or other approved methods. Verify that all additional guarding devices are installed and operating properly.	___ Pass ___ Fail	
4. Make sure the operator is not able to stand between the MS4800 system detection zone and the machine danger point. Verify that the light curtain can only be reset from a position outside and within view of the hazardous machine area.	___ Pass ___ Fail	
5. Inspect the electrical connections between the guarded machine's control system and the MS4800 system. Verify that they are properly connected to the machine such that a stop signal from the MS4800 system results in an immediate halt of the machine's cycle. See Section 10 -- <i>Connecting To The Machine Control Circuit</i> .	___ Pass ___ Fail	
6. If the EDM monitoring feature is not used, proceed to step 7. To test the EDM feature, verify that the feature has been enabled. Turn the machine power on. Cycle the machine. Place a temporary jumper wire between the EDM connections. The MS4800 should enter an alarm condition. Remove the temporary jumper. Press and release the start button.	___ Pass ___ Fail	
7. Record the test results in the machine log, then perform the Test Procedure.	___ Pass ___ Fail	

Technician

Signature: \_\_\_\_\_

# APPENDIX B —TEST PROCEDURE

## B.1 TEST PROCEDURE LOG

The following test procedure must be performed by qualified personnel during initial MS4800 system installation, according to the employer’s regular inspection program and after any maintenance, adjustment or modification to the MS4800 system or the guarded machine. Testing ensures that the light curtain, safety system, and machine control system work together to properly stop the machine. Failure to test properly could result in serious injury to personnel. To test the MS4800 system, use the correct size test object.

Machine Identification: \_\_\_\_\_ Date: \_\_\_\_\_

Item	Condition	Comments
1. Disable the guarded machine. Apply power to the MS4800 system.	___ Pass ___ Fail	
2. Visually inspect the machine to ensure that access to the danger point is only through the MS4800 detection zone. If not, additional guarding, including mechanical barriers may be required. Verify that all additional guarding devices and barriers are installed and operating properly.	___ Pass ___ Fail	
3. Verify that the mounting distance of the MS4800 system is equal to or greater than the calculated minimum safety distance from the danger point. See Section 8 -- <i>Safe Mounting Distance</i> for further information. Ensure that the operator is not able to stand between the 4800 detection zone and the danger point.	___ Pass ___ Fail	
4. Check for signs of external damage to the MS4800 system, the machine and the electrical cables and wiring. If damage is found, lock the machine off and report to the supervisor.	___ Pass ___ Fail	
5. Interrupt the MS4800 system detection zone with the proper size test object. Move the test object inside the perimeter (along the top, sides and bottom) of the detection zone and up and down through the center. At least one Individual Beam Indicator must be lit while the test object is anywhere in the detection zone. If in automatic start mode, verify that the red MACHINE STOP light is lit. If in start/restart INTERLOCK mode, verify that the red MACHINE STOP and yellow INTERLOCK lights are on. Press and release start button before proceeding to step 6.	___ Pass ___ Fail	
6. Start the machine. While the machine is in motion, interrupt the detection zone with the test object. The machine should stop immediately. Never insert the test object into the dangerous parts of the machine. With the machine at rest, interrupt the detection zone with the test object. Verify that the machine will not start with the test object in the detection zone.	___ Pass ___ Fail	
7. Verify that the braking system is working properly. If the machine does not stop fast enough, adjust the braking system or increase the distance from the detection zone to the danger point.	___ Pass ___ Fail	
8. If the safety devices or the machine fails any of these tests, do not run the machine. Immediately tag or LOCKOUT the machine to prevent its use and notify the supervisor.	___ Pass ___ Fail	

Technician  
Signature: \_\_\_\_\_

# Terms and Conditions of Sale

1. **Offer; Acceptance.** These terms and conditions (these "Terms") are deemed part of all quotes, agreements, purchase orders, acknowledgments, price lists, catalogs, manuals, brochures and other documents, whether electronic or in writing, relating to the sale of products or services (collectively, the "Products") by Omron Electronics LLC and its subsidiary companies ("Omron"). Omron objects to any terms or conditions proposed in Buyer's purchase order or other documents which are inconsistent with, or in addition to, these Terms.
2. **Prices; Payment Terms.** All prices stated are current, subject to change without notice by Omron. Omron reserves the right to increase or decrease prices on any unshipped portions of outstanding orders. Payments for Products are due net 30 days unless otherwise stated in the invoice.
3. **Discounts.** Cash discounts, if any, will apply only on the net amount of invoices sent to Buyer after deducting transportation charges, taxes and duties, and will be allowed only if (i) the invoice is paid according to Omron's payment terms and (ii) Buyer has no past due amounts.
4. **Interest.** Omron, at its option, may charge Buyer 1-1/2% interest per month or the maximum legal rate, whichever is less, on any balance not paid within the stated terms.
5. **Orders.** Omron will accept no order less than \$200 net billing.
6. **Governmental Approvals.** Buyer shall be responsible for, and shall bear all costs involved in, obtaining any government approvals required for the importation or sale of the Products.
7. **Taxes.** All taxes, duties and other governmental charges (other than general real property and income taxes), including any interest or penalties thereon, imposed directly or indirectly on Omron or required to be collected directly or indirectly by Omron for the manufacture, production, sale, delivery, importation, consumption or use of the Products sold hereunder (including customs duties and sales, excise, use, turnover and license taxes) shall be charged to and remitted by Buyer to Omron.
8. **Financial.** If the financial position of Buyer at any time becomes unsatisfactory to Omron, Omron reserves the right to stop shipments or require satisfactory security or payment in advance. If Buyer fails to make payment or otherwise comply with these Terms or any related agreement, Omron may (without liability and in addition to other remedies) cancel any unshipped portion of Products sold hereunder and stop any Products in transit until Buyer pays all amounts, including amounts payable hereunder, whether or not then due, which are owing to it by Buyer. Buyer shall in any event remain liable for all unpaid accounts.
9. **Cancellation; Etc.** Orders are not subject to rescheduling or cancellation unless Buyer indemnifies Omron against all related costs or expenses.
10. **Force Majeure.** Omron shall not be liable for any delay or failure in delivery resulting from causes beyond its control, including earthquakes, fires, floods, strikes or other labor disputes, shortage of labor or materials, accidents to machinery, acts of sabotage, riots, delay in or lack of transportation or the requirements of any government authority.
11. **Shipping; Delivery.** Unless otherwise expressly agreed in writing by Omron:
  - a. Shipments shall be by a carrier selected by Omron; Omron will not drop ship except in "break down" situations.
  - b. Such carrier shall act as the agent of Buyer and delivery to such carrier shall constitute delivery to Buyer;
  - c. All sales and shipments of Products shall be FOB shipping point (unless otherwise stated in writing by Omron), at which point title and risk of loss shall pass from Omron to Buyer; provided that Omron shall retain a security interest in the Products until the full purchase price is paid;
  - d. Delivery and shipping dates are estimates only; and
  - e. Omron will package Products as it deems proper for protection against normal handling and extra charges apply to special conditions.
12. **Claims.** Any claim by Buyer against Omron for shortage or damage to the Products occurring before delivery to the carrier must be presented in writing to Omron within 30 days of receipt of shipment and include the original transportation bill signed by the carrier noting that the carrier received the Products from Omron in the condition claimed.
13. **Warranties.** (a) **Exclusive Warranty.** Omron's exclusive warranty is that the Products will be free from defects in materials and workmanship for a period of twelve months from the date of sale by Omron (or such other period expressed in writing by Omron). Omron disclaims all other warranties, express or implied. (b) **Limitations.** OMRON MAKES NO WARRANTY OR REPRESENTATION, EXPRESS OR IMPLIED, ABOUT NON-INFRINGEMENT, MERCHANTABILITY OR FITNESS FOR A PARTICULAR PURPOSE OF THE PRODUCTS. BUYER ACKNOWLEDGES THAT IT ALONE HAS DETERMINED THAT THE PRODUCTS WILL SUITABLY MEET THE REQUIREMENTS OF THEIR INTENDED USE. Omron further disclaims all warranties and responsibility of any type for claims or expenses based on infringement by the Products or otherwise of any intellectual property right. (c) **Buyer Remedy.** Omron's sole obligation hereunder shall be, at Omron's election, to (i) replace (in the form originally shipped with Buyer responsible for labor charges for removal or replacement thereof) the non-complying Product, (ii) repair the non-complying Product, or (iii) repay or credit Buyer an amount equal to the purchase price of the non-complying Product; provided that in no event shall Omron be responsible for warranty, repair, indemnity or any other claims or expenses regarding the Products unless Omron's analysis confirms that the Products were properly handled, stored, installed and maintained and not subject to contamination, abuse, misuse or inappropriate modification. Return of any Products by Buyer must be approved in writing by Omron before shipment. Omron Companies shall not be liable for the suitability or unsuitability or the results from the use of Products in combination with any electrical or electronic components, circuits, system assemblies or any other materials or substances or environments. Any advice, recommendations or information given orally or in writing, are not to be construed as an amendment or addition to the above warranty. See <http://www.omron247.com> or contact your Omron representative for published information.
14. **Limitation on Liability; Etc.** OMRON COMPANIES SHALL NOT BE LIABLE FOR SPECIAL, INDIRECT, INCIDENTAL, OR CONSEQUENTIAL DAMAGES, LOSS OF PROFITS OR PRODUCTION OR COMMERCIAL LOSS IN ANY WAY CONNECTED WITH THE PRODUCTS, WHETHER SUCH CLAIM IS BASED IN CONTRACT, WARRANTY, NEGLIGENCE OR STRICT LIABILITY. Further, in no event shall liability of Omron Companies exceed the individual price of the Product on which liability is asserted.
15. **Indemnities.** Buyer shall indemnify and hold harmless Omron Companies and their employees from and against all liabilities, losses, claims, costs and expenses (including attorney's fees and expenses) related to any claim, investigation, litigation or proceeding (whether or not Omron is a party) which arises or is alleged to arise from Buyer's acts or omissions under these Terms or in any way with respect to the Products. Without limiting the foregoing, Buyer (at its own expense) shall indemnify and hold harmless Omron and defend or settle any action brought against such Companies to the extent based on a claim that any Product made to Buyer specifications infringed intellectual property rights of another party.
16. **Property; Confidentiality.** Any intellectual property in the Products is the exclusive property of Omron Companies and Buyer shall not attempt to duplicate it in any way without the written permission of Omron. Notwithstanding any charges to Buyer for engineering or tooling, all engineering and tooling shall remain the exclusive property of Omron. All information and materials supplied by Omron to Buyer relating to the Products are confidential and proprietary, and Buyer shall limit distribution thereof to its trusted employees and strictly prevent disclosure to any third party.
17. **Export Controls.** Buyer shall comply with all applicable laws, regulations and licenses regarding (i) export of products or information; (iii) sale of products to "forbidden" or other proscribed persons; and (ii) disclosure to non-citizens of regulated technology or information.
18. **Miscellaneous.** (a) **Waiver.** No failure or delay by Omron in exercising any right and no course of dealing between Buyer and Omron shall operate as a waiver of rights by Omron. (b) **Assignment.** Buyer may not assign its rights hereunder without Omron's written consent. (c) **Law.** These Terms are governed by the law of the jurisdiction of the home office of the Omron company from which Buyer is purchasing the Products (without regard to conflict of law principles). (d) **Amendment.** These Terms constitute the entire agreement between Buyer and Omron relating to the Products, and no provision may be changed or waived unless in writing signed by the parties. (e) **Severability.** If any provision hereof is rendered ineffective or invalid, such provision shall not invalidate any other provision. (f) **Setoff.** Buyer shall have no right to set off any amounts against the amount owing in respect of this invoice. (g) **Definitions.** As used herein, "including" means "including without limitation"; and "Omron Companies" (or similar words) mean Omron Corporation and any direct or indirect subsidiary or affiliate thereof.

## Certain Precautions on Specifications and Use

1. **Suitability of Use.** Omron Companies shall not be responsible for conformity with any standards, codes or regulations which apply to the combination of the Product in the Buyer's application or use of the Product. At Buyer's request, Omron will provide applicable third party certification documents identifying ratings and limitations of use which apply to the Product. This information by itself is not sufficient for a complete determination of the suitability of the Product in combination with the end product, machine, system, or other application or use. Buyer shall be solely responsible for determining appropriateness of the particular Product with respect to Buyer's application, product or system. Buyer shall take application responsibility in all cases but the following is a non-exhaustive list of applications for which particular attention must be given:
  - (i) Outdoor use, uses involving potential chemical contamination or electrical interference, or conditions or uses not described in this document.
  - (ii) Use in consumer products or any use in significant quantities.
  - (iii) Energy control systems, combustion systems, railroad systems, aviation systems, medical equipment, amusement machines, vehicles, safety equipment, and installations subject to separate industry or government regulations.
  - (iv) Systems, machines and equipment that could present a risk to life or property. Please know and observe all prohibitions of use applicable to this Product.

NEVER USE THE PRODUCT FOR AN APPLICATION INVOLVING SERIOUS RISK TO LIFE OR PROPERTY OR IN LARGE QUANTITIES WITHOUT ENSURING THAT THE SYSTEM AS A WHOLE HAS BEEN DESIGNED TO ADDRESS THE RISKS, AND THAT THE OMRON'S PRODUCT IS PROPERLY RATED AND INSTALLED FOR THE INTENDED USE WITHIN THE OVERALL EQUIPMENT OR SYSTEM.
2. **Programmable Products.** Omron Companies shall not be responsible for the user's programming of a programmable Product, or any consequence thereof.
3. **Performance Data.** Data presented in Omron Company websites, catalogs and other materials is provided as a guide for the user in determining suitability and does not constitute a warranty. It may represent the result of Omron's test conditions, and the user must correlate it to actual application requirements. Actual performance is subject to the Omron's Warranty and Limitations of Liability.
4. **Change in Specifications.** Product specifications and accessories may be changed at any time based on improvements and other reasons. It is our practice to change part numbers when published ratings or features are changed, or when significant construction changes are made. However, some specifications of the Product may be changed without any notice. When in doubt, special part numbers may be assigned to fix or establish key specifications for your application. Please consult with your Omron's representative at any time to confirm actual specifications of purchased Product.
5. **Errors and Omissions.** Information presented by Omron Companies has been checked and is believed to be accurate; however, no responsibility is assumed for clerical, typographical or proofreading errors or omissions.

**OMRON AUTOMATION AND SAFETY • THE AMERICAS HEADQUARTERS** • Chicago, IL USA • 847.843.7900 • 800.556.6766 • [www.omron247.com](http://www.omron247.com)

**OMRON CANADA, INC. • HEAD OFFICE**

Toronto, ON, Canada • 416.286.6465 • 866.986.6766 • [www.omron247.com](http://www.omron247.com)

**OMRON ELECTRONICS DE MEXICO • HEAD OFFICE**

México DF • 52.55.59.01.43.00 • 01-800-226-6766 • [mela@omron.com](mailto:mela@omron.com)

**OMRON ELECTRONICS DE MEXICO • SALES OFFICE**

Apodaca, N.L. • 52.81.11.56.99.20 • 01-800-226-6766 • [mela@omron.com](mailto:mela@omron.com)

**OMRON ELETRÔNICA DO BRASIL LTDA • HEAD OFFICE**

São Paulo, SP, Brasil • 55.11.2101.6300 • [www.omron.com.br](http://www.omron.com.br)

**OMRON ARGENTINA • SALES OFFICE**

Cono Sur • 54.11.4783.5300

**OMRON CHILE • SALES OFFICE**

Santiago • 56.9.9917.3920

**OTHER OMRON LATIN AMERICA SALES**

54.11.4783.5300

**OMRON EUROPE B.V.** • Wegalaan 67-69, NL-2132 JD, Hoofddorp, The Netherlands. • +31 (0) 23 568 13 00 • [www.industrial.omron.eu](http://www.industrial.omron.eu)

*Authorized Distributor:*

**Automation Control Systems**

- Machine Automation Controllers (MAC) • Programmable Controllers (PLC)
- Operator interfaces (HMI) • Distributed I/O • Software

**Drives & Motion Controls**

- Servo & AC Drives • Motion Controllers & Encoders

**Temperature & Process Controllers**

- Single and Multi-loop Controllers

**Sensors & Vision**

- Proximity Sensors • Photoelectric Sensors • Fiber-Optic Sensors
- Amplified Photomicrosensors • Measurement Sensors
- Ultrasonic Sensors • Vision Sensors

**Industrial Components**

- RFID/Code Readers • Relays • Pushbuttons & Indicators
- Limit and Basic Switches • Timers • Counters • Metering Devices
- Power Supplies

**Safety**

- Laser Scanners • Safety Mats • Edges and Bumpers • Programmable Safety Controllers • Light Curtains • Safety Relays • Safety Interlock Switches