



RF Power LDMOS Transistor

N-Channel Enhancement-Mode Lateral MOSFET

This 107 W asymmetrical Doherty RF power LDMOS transistor is designed for cellular base station applications covering the frequency range of 720 to 960 MHz.

900 MHz

- Typical Doherty Single-Carrier W-CDMA Performance: $V_{DD} = 48$ Vdc, $I_{DQA} = 800$ mA, $V_{GSB} = 0.7$ Vdc, $P_{out} = 107$ W Avg., Input Signal PAR = 9.9 dB @ 0.01% Probability on CCDF.

Frequency	G_{ps} (dB)	η_D (%)	Output PAR (dB)	ACPR (dBc)
920 MHz	18.6	53.6	7.6	-31.1
940 MHz	18.6	53.2	7.8	-33.3
960 MHz	18.5	53.5	7.9	-34.7

Features

- Advanced high performance in-package Doherty
- Greater negative gate-source voltage range for improved Class C operation
- Designed for digital predistortion error correction systems

A3V09H521-24SR6

**720–960 MHz, 107 W AVG., 48 V
 AIRFAST RF POWER LDMOS
 TRANSISTOR**

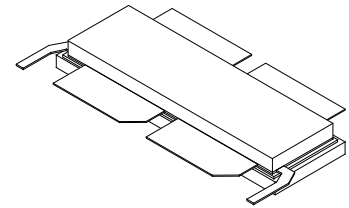

NI-1230S-4L2L

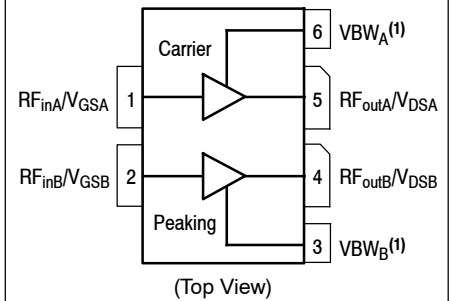

Figure 1. Pin Connections

1. Device cannot operate with V_{DD} current supplied through pin 3 and pin 6.

Table 1. Maximum Ratings

Rating	Symbol	Value	Unit
Drain-Source Voltage	V_{DSS}	-0.5, +100	Vdc
Gate-Source Voltage	V_{GS}	-6.0, +10	Vdc
Operating Voltage	V_{DD}	55, +0	Vdc
Storage Temperature Range	T_{stg}	-65 to +150	°C
Case Operating Temperature Range	T_C	-40 to +150	°C
Operating Junction Temperature Range (1,2)	T_J	-40 to +225	°C

Table 2. Thermal Characteristics

Characteristic	Symbol	Value (2,3)	Unit
Thermal Resistance, Junction to Case Case Temperature 74°C, 107 W Avg., W-CDMA, 48 Vdc, $I_{DQA} = 800$ mA, $V_{GSB} = 0.7$ Vdc, 940 MHz	$R_{\theta JC}$	0.37	°C/W

Table 3. ESD Protection Characteristics

Test Methodology	Class
Human Body Model (per JS-001-2017)	2
Charge Device Model (per JS-002-2014)	C3

Table 4. Electrical Characteristics ($T_A = 25^\circ\text{C}$ unless otherwise noted)

Characteristic	Symbol	Min	Typ	Max	Unit
----------------	--------	-----	-----	-----	------

Off Characteristics (4)

Zero Gate Voltage Drain Leakage Current ($V_{DS} = 100$ Vdc, $V_{GS} = 0$ Vdc)	I_{DSS}	—	—	10	μAdc
Zero Gate Voltage Drain Leakage Current ($V_{DS} = 55$ Vdc, $V_{GS} = 0$ Vdc)	I_{DSS}	—	—	1	μAdc
Gate-Source Leakage Current ($V_{GS} = 5$ Vdc, $V_{DS} = 0$ Vdc)	I_{GSS}	—	—	1	μAdc

On Characteristics — Side A, Carrier

Gate Threshold Voltage ($V_{DS} = 10$ Vdc, $I_D = 137$ μAdc)	$V_{GS(th)}$	1.3	1.8	2.3	Vdc
Gate Quiescent Voltage ($V_{DD} = 48$ Vdc, $I_{DA} = 800$ mAdc, Measured in Functional Test)	$V_{GSA(Q)}$	2.0	2.5	2.8	Vdc
Drain-Source On-Voltage ($V_{GS} = 10$ Vdc, $I_D = 1.37$ Adc)	$V_{DS(on)}$	0.1	0.3	0.5	Vdc

On Characteristics — Side B, Peaking

Gate Threshold Voltage ($V_{DS} = 10$ Vdc, $I_D = 274$ μAdc)	$V_{GS(th)}$	1.3	1.8	2.3	Vdc
Drain-Source On-Voltage ($V_{GS} = 10$ Vdc, $I_D = 2.74$ Adc)	$V_{DS(on)}$	0.1	0.3	0.5	Vdc

1. Continuous use at maximum temperature will affect MTF.
2. MTF calculator available at <http://www.nxp.com/RF/calculators>.
3. Refer to AN1955, *Thermal Measurement Methodology of RF Power Amplifiers*. Go to <http://www.nxp.com/RF> and search for AN1955.
4. Each side of device measured separately.

(continued)

Table 4. Electrical Characteristics ($T_A = 25^\circ\text{C}$ unless otherwise noted) (continued)

Characteristic	Symbol	Min	Typ	Max	Unit
Functional Tests ^(1,2) (In NXP Doherty Test Fixture, 50 ohm system) $V_{DD} = 48\text{ Vdc}$, $I_{DQA} = 800\text{ mA}$, $V_{GSB} = 0.7\text{ Vdc}$, $P_{out} = 107\text{ W Avg.}$, $f = 960\text{ MHz}$, Single-Carrier W-CDMA, IQ Magnitude Clipping, Input Signal PAR = 9.9 dB @ 0.01% Probability on CCDF. ACPR measured in 3.84 MHz Channel Bandwidth @ $\pm 5\text{ MHz}$ Offset.					
Power Gain	G_{ps}	17.6	18.5	20.6	dB
Drain Efficiency	η_D	51.0	53.5	—	%
Output Peak-to-Average Ratio @ 0.01% Probability on CCDF	PAR	7.4	7.9	—	dB
Adjacent Channel Power Ratio	ACPR	—	-34.7	-31.0	dBc
Load Mismatch ⁽²⁾ (In NXP Doherty Test Fixture, 50 ohm system) $I_{DQA} = 800\text{ mA}$, $V_{GSB} = 0.7\text{ Vdc}$, $f = 940\text{ MHz}$, 12 $\mu\text{sec(ON)}$, 10% Duty Cycle					
VSWR 10:1 at 55 Vdc, 776 W Pulsed CW Output Power (3 dB Input Overdrive from 568 W Pulsed CW Rated Power)	No Device Degradation				

Typical Performance ⁽²⁾ (In NXP Doherty Test Fixture, 50 ohm system) $V_{DD} = 48\text{ Vdc}$, $I_{DQA} = 800\text{ mA}$, $V_{GSB} = 0.7\text{ Vdc}$, 920–960 MHz Bandwidth

P_{out} @ 3 dB Compression Point ⁽³⁾	P3dB	—	661	—	W
AM/PM (Maximum value measured at the P3dB compression point across the 920–960 MHz frequency range)	Φ	—	-21	—	°
VBW Resonance Point (IMD Third Order Intermodulation Inflection Point)	VBW _{res}	—	80	—	MHz
Gain Flatness in 40 MHz Bandwidth @ $P_{out} = 107\text{ W Avg.}$	G_F	—	0.1	—	dB
Gain Variation over Temperature (-40°C to +85°C)	ΔG	—	0.01	—	dB/°C
Output Power Variation over Temperature (-40°C to +85°C)	ΔP_{1dB}	—	0.003	—	dB/°C

Table 5. Ordering Information

Device	Tape and Reel Information	Package
A3V09H521-24SR6	R6 Suffix = 150 Units, 56 mm Tape Width, 13-inch Reel	NI-1230S-4L2L

- Part internally matched both on input and output.
- Measurement made with device in an asymmetrical Doherty configuration.
- P3dB = $P_{avg} + 7.0\text{ dB}$ where P_{avg} is the average output power measured using an unclipped W-CDMA single-carrier input signal where output PAR is compressed to 7.0 dB @ 0.01% probability on CCDF.

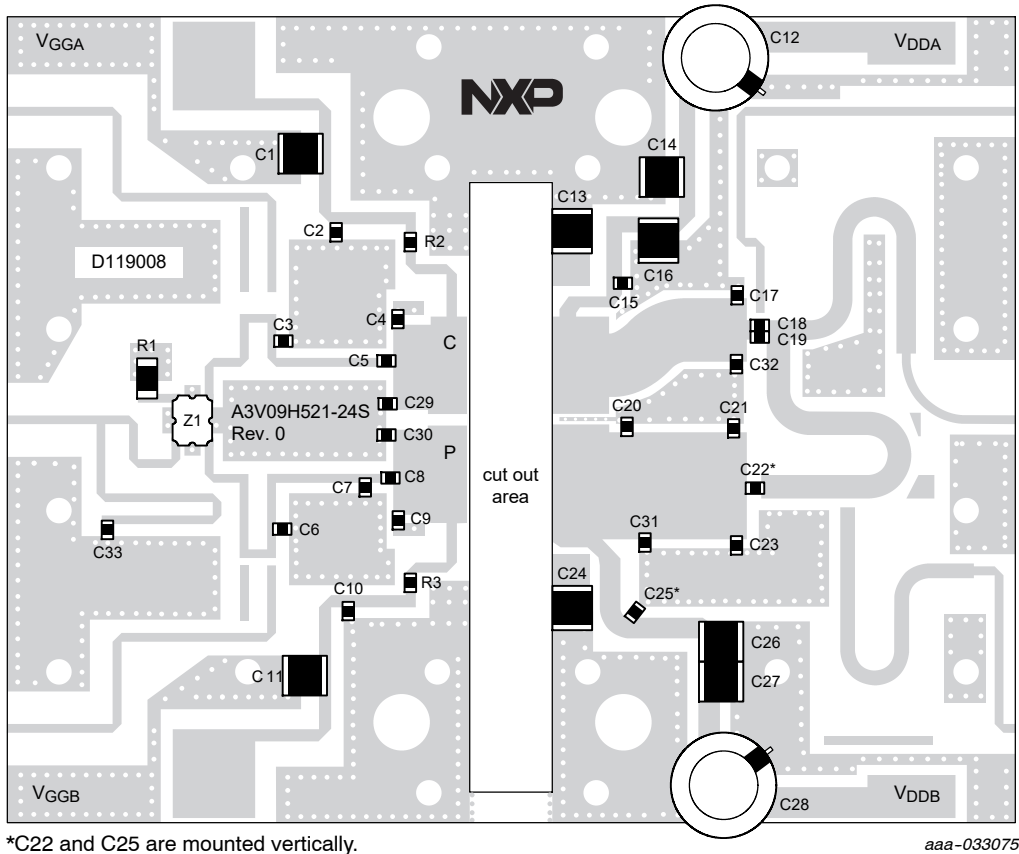
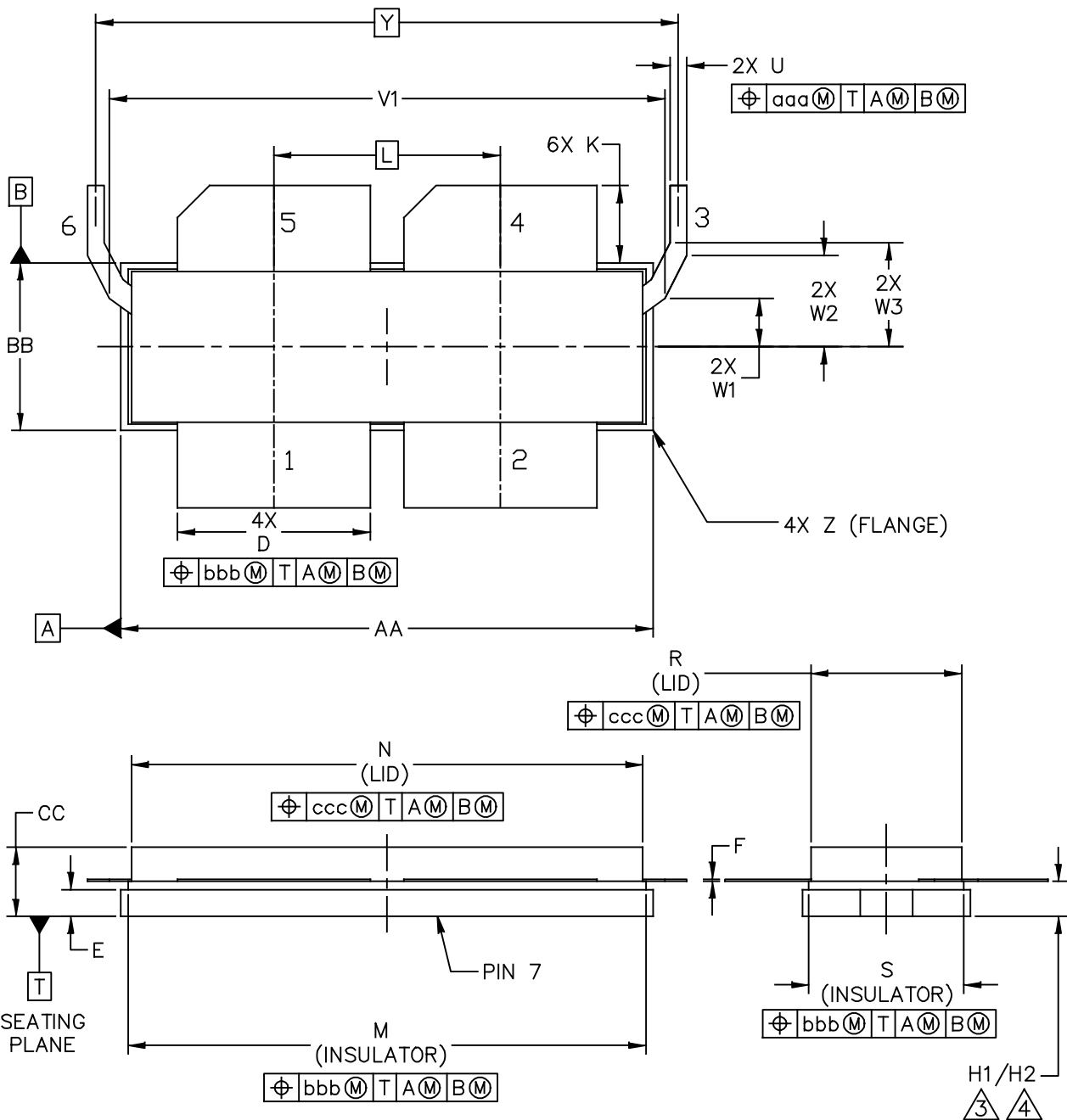

Figure 2. A3V09H521-24SR6 Test Circuit Component Layout

Table 6. A3V09H521-24SR6 Test Circuit Component Designations and Values

Part	Description	Part Number	Manufacturer
C1, C11, C13, C14, C16, C24, C26, C27	10 μ F Chip Capacitor	C5750X7S2A106M230KB	TDK
C2, C5, C8, C10, C15, C18, C19	39 pF Chip Capacitor	ATC600F390JT250XT	ATC
C3, C30	3.3 pF Chip Capacitor	ATC600F3R3BT250XT	ATC
C4, C9	8.2 pF Chip Capacitor	ATC600F8R2BT250XT	ATC
C6	2.7 pF Chip Capacitor	ATC600F2R7BT250XT	ATC
C7	5.6 pF Chip Capacitor	ATC600F5R6BT250XT	ATC
C12, C28	470 μ F, 100 V Electrolytic Capacitor	MCGPR100V477M16X32	Multicomp
C17, C32	3.0 pF Chip Capacitor	ATC600F3R0BT250XT	ATC
C20, C23	4.7 pF Chip Capacitor	ATC600F4R7BT250XT	ATC
C21	4.3 pF Chip Capacitor	ATC600F4R3BT250XT	ATC
C22	22 pF Chip Capacitor	ATC100B220JT500XT	ATC
C25	39 pF Chip Capacitor	ATC100B390JT500XT	ATC
C29	1.2 pF Chip Capacitor	ATC600F1R2BT250XT	ATC
C31	1.5 pF Chip Capacitor	ATC600F1R5BT250XT	ATC
C33	110 pF Chip Capacitor	ATC100B111JT300XT	ATC
R1	50 Ω , 4 W Chip Resistor	CW12010T0050GBK	ATC
R2, R3	6.8 Ω , 1/4 W Chip Resistor	CRCW12066R80FKEA	Vishay
Z1	800–1000 MHz, 90°, 2 dB Asymmetric Coupler	CMX09Q02	RN2 Technologies
PCB	RO4350B, 0.020", $\epsilon_r = 3.66$	D119008	MTL

PACKAGE DIMENSIONS



© NXP SEMICONDUCTORS N.V. ALL RIGHTS RESERVED	MECHANICAL OUTLINE	PRINT VERSION NOT TO SCALE
TITLE: NI-1230-4LS2L	DOCUMENT NO: 98ASA00513D	REV: B
	STANDARD: NON-JEDEC	
	SOT1800-1	08 FEB 2016

A3V09H521-24SR6

NOTES:

1. INTERPRET DIMENSIONS AND TOLERANCES PER ASME Y14.5M-1994.
2. CONTROLLING DIMENSION: INCH

3. DIMENSIONS H1 AND H2 ARE MEASURED .030 INCH (0.762 MM) AWAY FROM FLANGE PARALLEL TO DATUM B. H1 APPLIES TO PINS 1, 2, 4 & 5. H2 APPLIES TO PINS 3 & 6.

4. TOLERANCE OF DIMENSION H2 IS TENTATIVE AND COULD CHANGE ONCE SUFFICIENT MANUFACTURING DATA IS AVAILABLE.

DIM	INCH		MILLIMETER		DIM	INCH		MILLIMETER	
	MIN	MAX	MIN	MAX		MIN	MAX	MIN	MAX
AA	1.265	1.275	32.13	32.39	N	1.218	1.242	30.94	31.55
BB	.395	.405	10.03	10.29	R	.365	.375	9.27	9.53
CC	.170	.190	4.32	4.83	S	.365	.375	9.27	9.53
D	.455	.465	11.56	11.81	U	.035	.045	0.89	1.14
E	.062	.066	1.57	1.68	V1	1.320	1.330	33.53	33.78
F	.004	.007	0.10	0.18	W1	.110	.120	2.79	3.05
H1	.082	.090	2.08	2.29	W2	.213	.223	5.41	5.66
H2	.078	.094	1.98	2.39	W3	.243	.253	6.17	6.43
K	.175	.195	4.45	4.95	Y	1.390 BSC		35.31 BSC	
L	.540 BSC		13.72 BSC		Z	R.000	R.040	R0.00	R1.02
M	1.219	1.241	30.96	31.52	aaa	.015		0.38	
					bbb	.010		0.25	
					ccc	.020		0.51	
© NXP SEMICONDUCTORS N.V. ALL RIGHTS RESERVED			MECHANICAL OUTLINE			PRINT VERSION NOT TO SCALE			
TITLE:					DOCUMENT NO: 98ASA00513D		REV: B		
NI-1230-4LS2L					STANDARD: NON-JEDEC				
					SOT1800-1		08 FEB 2016		

PRODUCT DOCUMENTATION, SOFTWARE AND TOOLS

Refer to the following resources to aid your design process.

Application Notes

- AN1908: Solder Reflow Attach Method for High Power RF Devices in Air Cavity Packages
- AN1955: Thermal Measurement Methodology of RF Power Amplifiers

Engineering Bulletins

- EB212: Using Data Sheet Impedances for RF LDMOS Devices

Software

- Electromigration MTTF Calculator
- .s2p File

Development Tools

- Printed Circuit Boards

To Download Resources Specific to a Given Part Number:

1. Go to <http://www.nxp.com/RF>
2. Search by part number
3. Click part number link
4. Choose the desired resource from the drop down menu

REVISION HISTORY

The following table summarizes revisions to this document.

Revision	Date	Description
0	Feb. 2019	<ul style="list-style-type: none">• Initial release of data sheet

How to Reach Us:

Home Page:
nxp.com

Web Support:
nxp.com/support

Information in this document is provided solely to enable system and software implementers to use NXP products. There are no express or implied copyright licenses granted hereunder to design or fabricate any integrated circuits based on the information in this document. NXP reserves the right to make changes without further notice to any products herein.

NXP makes no warranty, representation, or guarantee regarding the suitability of its products for any particular purpose, nor does NXP assume any liability arising out of the application or use of any product or circuit, and specifically disclaims any and all liability, including without limitation consequential or incidental damages. "Typical" parameters that may be provided in NXP data sheets and/or specifications can and do vary in different applications, and actual performance may vary over time. All operating parameters, including "typicals," must be validated for each customer application by customer's technical experts. NXP does not convey any license under its patent rights nor the rights of others. NXP sells products pursuant to standard terms and conditions of sale, which can be found at the following address: nxp.com/SalesTermsandConditions.

NXP, the NXP logo and Airfast are trademarks of NXP B.V. All other product or service names are the property of their respective owners.

© 2019 NXP B.V.